



FREEPLAY



OWNER'S MANUAL



Important Safety Instructions

1. Read these instructions.
2. Keep these instructions.
3. Heed all warnings.
4. Follow all instructions.
5. Do not use this apparatus near water.
6. Clean only with a dry cloth.
7. Do not block any ventilation openings. Install in accordance with the manufacturer's instructions.
8. Do not install near any heat sources such as radiators, heat registers, stoves, or other apparatus (including amplifiers) that produce heat.
9. Protect the power cord from being walked on or pinched particularly at plugs, convenience receptacles, and the point where they exit from the apparatus.
10. Only use attachments/accessories specified by the manufacturer.
11. Use only with a cart, stand, tripod, bracket, or table specified by the manufacturer, or sold with the apparatus. When a cart is used, use caution when moving the cart/apparatus combination to avoid injury from tip-over.
12. Unplug this apparatus during lightning storms or when unused for long periods of time.
13. Refer all servicing to qualified service personnel. Servicing is required when the apparatus has been damaged in any way, such as power-supply cord or plug is damaged, liquid has been spilled or objects have fallen into the apparatus, the apparatus has been exposed to rain or moisture, does not operate normally, or has been dropped.
14. This apparatus shall not be exposed to dripping or splashing, and no object filled with liquids, such as vases or beer glasses, shall be placed on the apparatus.
15. Do not overload wall outlets and extension cords as this can result in a risk of fire or electric shock.
16. **NOTE:** This equipment has been tested and found to comply with the limits for a Class B digital device, pursuant to part 15 of the FCC Rules. These limits are designed to provide reasonable protection against harmful interference in a residential installation. This equipment generates, uses, and can radiate radio frequency energy and, if not installed and used in accordance with the instructions, may cause harmful interference to radio communications. However, there is no guarantee that interference will not occur in a particular installation. If this equipment does cause harmful interference to radio or television reception, which can be determined by turning the equipment off and on, the user is encouraged to try to correct the interference by one or more of the following measures:

- Reorient or relocate the receiving antenna.
- Increase the separation between the equipment and the receiver.
- Connect the equipment into an outlet on a circuit different from that to which the receiver is connected.
- Consult the dealer or an experienced radio/TV technician for help.

CAUTION: Changes or modifications to this device not expressly approved by LOUD Audio, LLC could void the user's authority to operate the equipment under FCC rules.



CAUTION

RISK OF ELECTRIC SHOCK! DO NOT OPEN!

CAUTION: TO REDUCE THE RISK OF ELECTRIC SHOCK DO NOT REMOVE COVER (OR BACK). NO USER-SERVICEABLE PARTS INSIDE. REFER SERVICING TO QUALIFIED PERSONNEL.

The lightning flash with arrowhead symbol within an equilateral triangle is intended to alert the user to the presence of uninsulated "dangerous voltage" within the product's enclosure, that may be of significant magnitude to constitute a risk of electric shock to persons.

The exclamation point within an equilateral triangle is intended to alert the user of the presence of important operating and maintaining (servicing) instructions in the literature accompanying the appliance.

WARNING — To reduce the risk of fire or electric shock, do not expose this apparatus to rain or moisture.

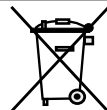

Correct disposal of this product: This symbol indicates that this product should not be disposed of with your household waste, according to the WEEE directive (2012/19/EU) and your national law. This product should be handed over to an authorized collection site for recycling waste electrical and electronic equipment (EEE). Improper handling of this type of waste could have a possible negative impact on the environment and human health due to potentially hazardous substances that are generally associated with EEE. At the same time, your cooperation in the correct disposal of this product will contribute to the effective usage of natural resources. For more information about where you can drop off your waste equipment for recycling, please contact your local city office, waste authority, or your household waste disposal service.

17. This device complies with FCC radiation exposure limits set forth for an uncontrolled environment. This device should be installed and operated with minimum distance 20cm between the radiator & your body.
 18. The maximum ambient temperature during use of the appliance must not exceed 45° C.
 19. Operation frequency: 2402MHz – 2480MHz
 20. RF POWER = <19dBm
 21. This apparatus does not exceed the Class A/Class B (whichever is applicable) limits for radio noise emissions from digital apparatus as set out in the radio interference regulations of the Canadian Department of Communications.
- ATTENTION** — *Le présent appareil numérique n'émet pas de bruits radioélectriques dépassant les limites applicables aux appareils numériques de class A/de class B (selon le cas) prescrites dans le règlement sur le brouillage radioélectrique édicté par les ministere des communications du Canada.*
22. This device complies with Industry Canada licence-exempt RSS standard(s). Operation is subject to the following two conditions:
 - (1) this device may not cause interference, and
 - (2) this device must accept any interference, including interference that may cause undesired operation of the device.

Le présent appareil est conforme aux CNR d'Industrie Canada applicables aux appareils radio exempts de licence. L'exploitation est autorisée aux deux conditions suivantes :

 - (1) l'appareil ne doit pas produire de brouillage, et
 - (2) l'utilisateur de l'appareil doit accepter tout brouillage radioélectrique subi, même si le brouillage est susceptible d'en compromettre le fonctionnement.
 23. Exposure to extremely high noise levels may cause permanent hearing loss. Individuals vary considerably in susceptibility to noise-induced hearing loss, but nearly everyone will lose some hearing if exposed to sufficiently intense noise for a period of time. The U.S. Government's Occupational Safety and Health Administration (OSHA) has specified the permissible noise level exposures shown in the following chart.

According to OSHA, any exposure in excess of these permissible limits could result in some hearing loss. To ensure against potentially dangerous exposure to high sound pressure levels, it is recommended that all persons exposed to equipment capable of producing high sound pressure levels use hearing protectors while the equipment is in operation. Ear plugs or protectors in the ear canals or over the ears must be worn when operating the equipment in order to prevent permanent hearing loss if exposure is in excess of the limits set forth here:

Duration, per day in hours	Sound Level dBA, Slow Response	Typical Example
8	90	Duo in small club
6	92	
4	95	Subway Train
3	97	
2	100	Very loud classical music
1.5	102	
1	105	Ryan screaming at Troy about deadlines
0.5	110	
0.25 or less	115	Loudest parts at a rock concert

WARNING — The battery (battery or batteries or battery pack) shall not be exposed to excessive heat such as sunshine, fire or the like.

CAUTION — Danger of explosion if battery is incorrectly replaced. Replace only with the same or equivalent type.

Laite on liitettävä suojakoskettimilla varustettuun pistorasiaan.

Apparatet må tilkoples jordat stikkontakt.

Apparaten skall anslutas till jordat uttag.

Contents

Important Safety Instructions	2
Contents	3
Features.....	3
Introduction	4
How To Use This Manual.....	4
Getting Started	4
Things To Remember	4
Hookup Diagrams	5
FreePlay LIVE: Rear Panel Features.....	7
FreePlay Connect App.....	7
1. Power Connector.....	7
2. Power Switch.....	7
3. XLR and 1/4" Combo Inputs	7
4. Bluetooth / Aux Input.....	8
5. Mon Out.....	8
6. Pole Mount.....	8
FreePlay LIVE: Top Panel Features.....	9
7. Bluetooth Button.....	9
8. Channel 1 and 2 Button	9
9. Level [+ and -] Buttons	9
10. Meters	9
11. RVB	9
12. EQ Mode.....	10
Handle	10
Speaker Link.....	10
Factory Reset [aka Vulcan Mind Meld]	11
AC Power	11
Care and Maintenance	11
Appendix A: Service Information.....	12
Appendix B: Technical Information	13
FreePlay LIVE Dimensions	14
FreePlay LIVE Block Diagram	15
Limited Warranty.....	16

Features

- The Power Performers Demand
 - 150W total power drives a high-output 6" woofer and dual tweeters for powerful, room-filling sound
 - Built-in rechargeable lithium-ion battery for up to 15 hours* of continuous operation
 - Perform, Present, Play
 - Dual 1/4" / XLR combo inputs for connecting guitars, microphones, keyboards, and more
 - 1/4" balanced monitor out for sending your mix to another powered speaker or mixer
 - 1/8" aux input
 - Wireless Bluetooth Streaming
 - Connect your device to FreePlay LIVE™ and enjoy your favorite tunes like you're at the show
 - Stage-Worthy Design
 - FreePlay LIVE features a durable molded enclosure, coated metal grille, and robust internal construction
 - Precision-Tuned Ported Enclosure
 - Enhanced bass and headroom for bigger, better sound that you can feel
 - FreePlay Connect™ Companion App
 - Download the free app and get complete control over levels, EQ, reverb, and more
 - Double The Fun
 - Link to a second FreePlay Series speaker for even bigger, clearer stereo sound or split them up for an immersive multi-room music listening experience
 - Included adapter allows for mounting on a standard microphone stand
- * Battery life will vary depending on volume and music content

Please write the serial numbers here for future reference (i.e., insurance claims, tech support, return authorization, make dad proud, etc.)

Purchased at:

Date of purchase:



Like us



Follow us



Watch our dang videos

Introduction

As a LIVE musician, public presenter, or anyone else who's had to ensure their audience can hear them clearly, you've almost certainly run into the shortcomings of most portable live sound speaker systems. They're either too big and heavy to easily transport and set up, or they're small but don't offer the power, sound quality, and reliability you need for your most confident performances.

Push those concerns aside. Mackie's new FreePlay LIVE™ is the perfect personal PA for anyone who needs a lightweight and great-sounding solution for music performance and speech presentations with plenty of power on tap. It can run on either AC or battery power, with the built-in high-capacity rechargeable battery offering up to 15 hours of rich, powerful sound.

FreePlay LIVE is flexible, with inputs for your microphone, guitar, keyboard, or playback device. You can also stream music wirelessly from any Bluetooth® enabled device. Plus, with the FreePlay Connect™ app, you get mobile freedom to control everything from levels to EQ for amazing sound in any situation and wirelessly link to a second FreePlay Series Bluetooth speaker for music playback.

So get ready to rock that coffeehouse. To host that open jam on the beach. To give that presentation to the sales team, or to lead that rally in the park. FreePlay LIVE gives you the freedom to be confident with your sound no matter where you go or what you do.

How to Use This Manual

After this introduction, a getting started guide will help you get things set up fast. The hookup diagrams show typical setups.



This icon marks information that is critically important or unique to the FreePlay LIVE. For your own good, read and remember them.



This icon leads you to in-depth explanations of features and practical tips. They usually have some valuable nuggets of information.



This icon draws attention to certain features and functions relating to the usage of FreePlay LIVE.

Getting Started

The following steps will help you set up the FreePlay LIVE quickly.

1. Make all initial connections with the power switch OFF.
2. Plug signal sources into FreePlay LIVE, such as:
 - Microphones plugged into the mic inputs.
 - Instrument level sources, such as acoustic guitars w/pickups into the instrument inputs.
 - Line-level sources such as keyboards, drum machines, or MP3 players plugged into the line-level inputs.
3. Connect the power adapter connector of the Power Block to the FreePlay LIVE. Push the line cord securely into the Power Block and plug the other end into a grounded AC outlet.
4. Turn FreePlay LIVE on.
5. Pair and connect a smart phone or tablet via Bluetooth.
6. Be sure that the volume of the inputs are the same as they would be during normal use.
7. Slowly bring up the main output level to a comfortable listening level.

Things to Remember

- Never listen to loud music for prolonged periods. Please see the Safety Instructions on page 2 for information on hearing protection.
- Save the shipping boxes and packing materials! You may need them someday. Besides, your cat will love playing in them and jumping out at you unexpectedly. Remember to pretend like you are surprised!
- Save your sales receipt in a safe place.

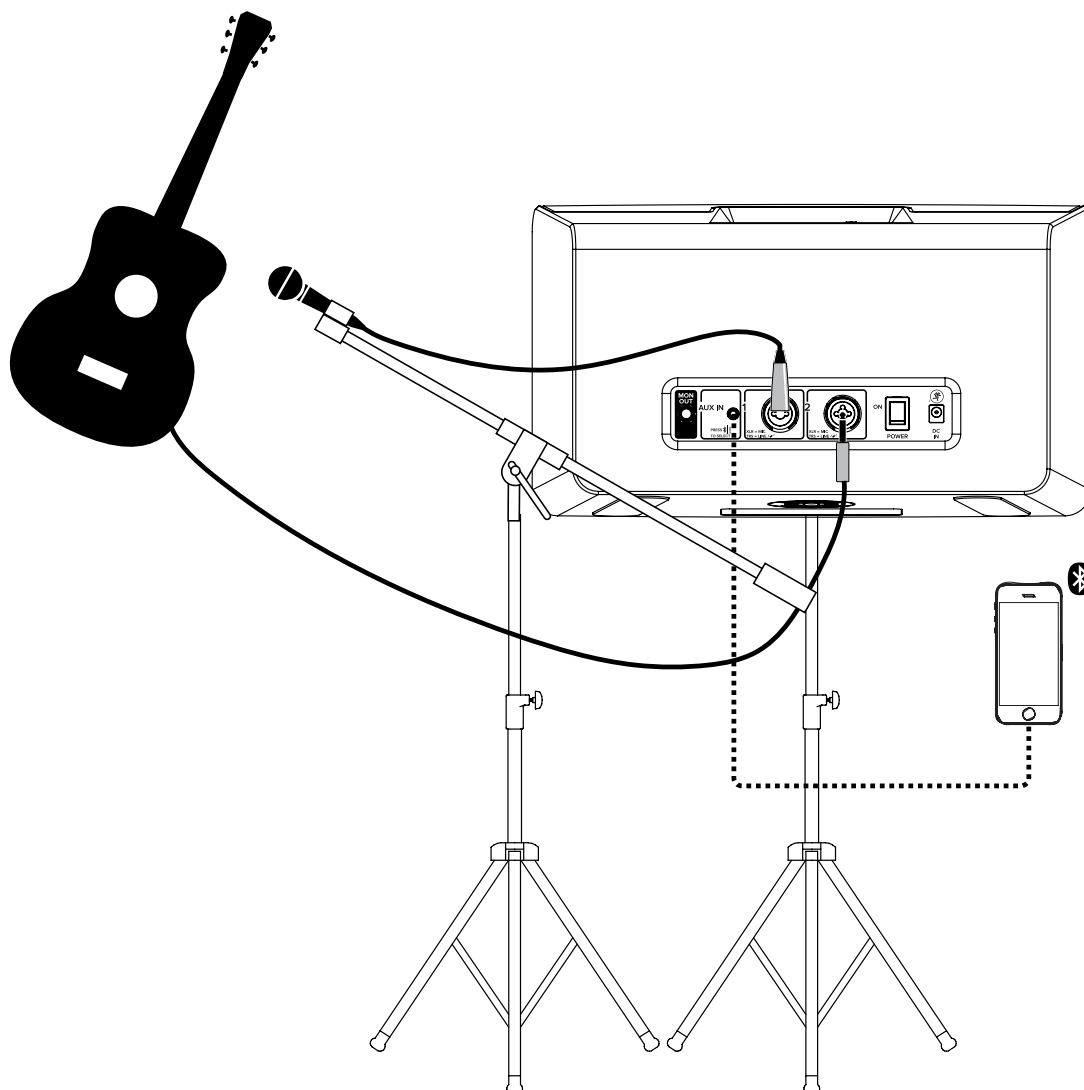

FreePlay LIVE is the perfect tool for singer-songwriters busking at the local hot spots or touring the world on the highly coveted coffee shop tour.

Along with FreePlay LIVE, bring your favorite axe and mic, cables and power cords. And your Bluetooth device, too...don't forget that! With it, you're able to announce tour dates via social media. More importantly, you can connect to FreePlay LIVE via Bluetooth (or 1/8" input) and jam along to the backing tracks you added.

In this example, a mic is connected to the channel 1 input. Adjust the level as described on page 9. Now grab your guitar and plug it directly into the channel 2 input. Adjust the level for the guitar now.

For the output, you will want to set an EQ mode, described in detail on page 9. For this type of setup, live mode works well.

Café Setup

FreePlay LIVE Hookup Diagrams continued...

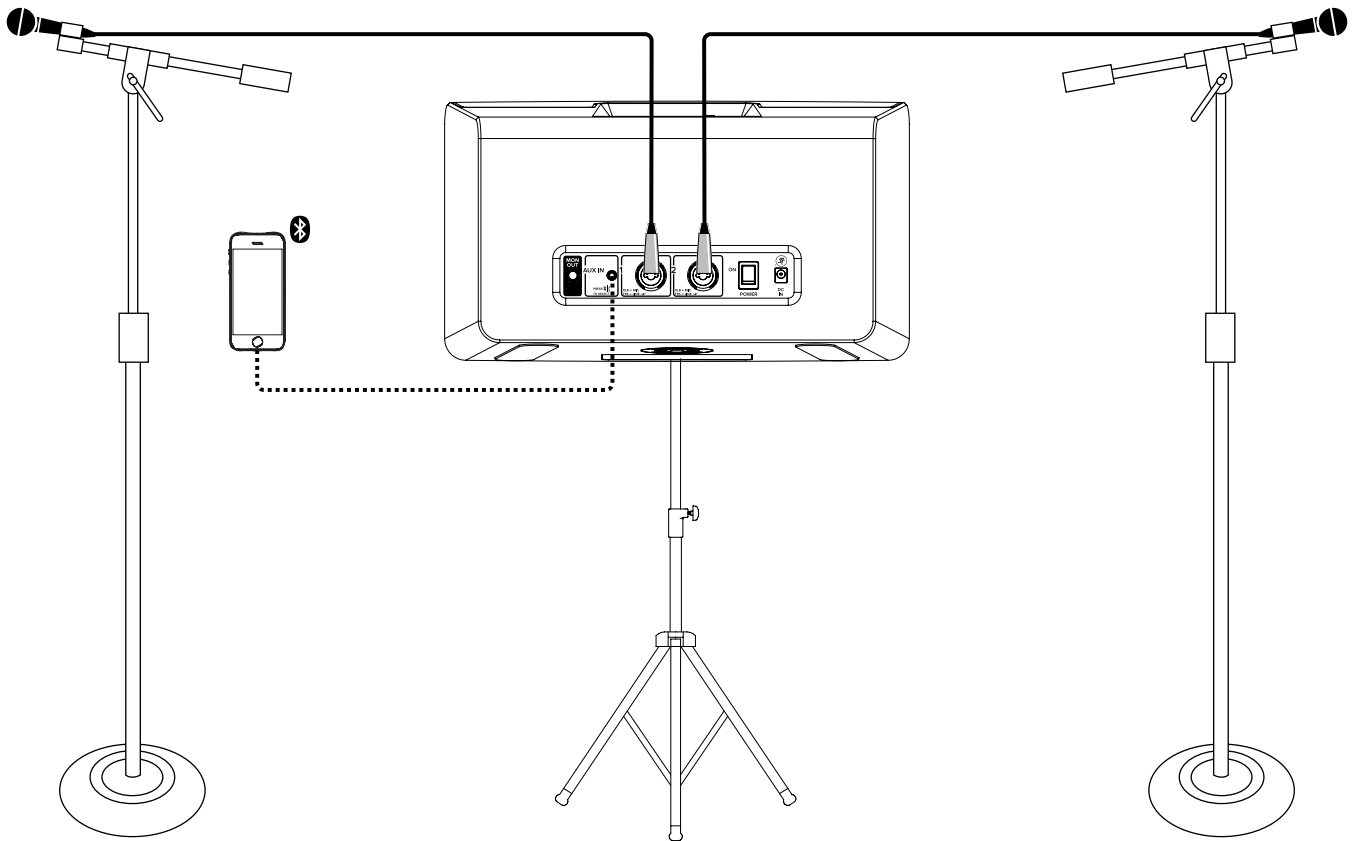

FreePlay may be used for presentations and karaoke, too...and the setup can remain as-is for both!

In this example, mics are connected to the channel 1 and channel 2 input jacks and a smartphone is connected via Bluetooth (or 1/8" input). Setting levels is described on page 9.

For the output, you will want to set an EQ mode, described in detail on page 9. For this type of setup, either EQ mode may be utilized: music EQ mode (for presentations) or live EQ mode (for karaoke).

You can do the presentation, but I'd be happy to do a karaoke duet! Neil Diamond's 'Sweet Caroline', anyone?

Presentation / Karaoke Setup

FreePlay LIVE: Rear Panel Features

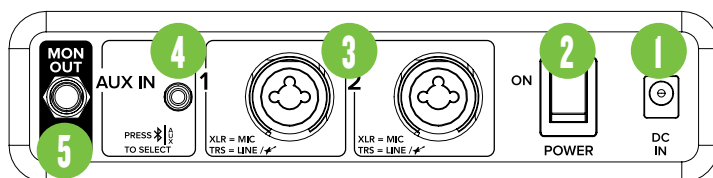

FreePlay Connect App

FreePlay LIVE is designed to be used in conjunction with the FreePlay Connect App. With it, all of the hardware features listed here – and more! – may be controlled remotely via Bluetooth connection. The only thing the FreePlay Connect App can't do is turn the unit on and off or pair a Bluetooth device.

More information about the FreePlay Connect App may be found by visiting the FreePlay Connect App Reference Guide.

1. Power Connector

FreePlay LIVE has a universal external power supply that accepts any AC voltage ranging from 100 VAC to 240 VAC. No need for voltage select switches. It will work virtually anywhere in the world. That's why we call it a "Planet Earth" power supply! It is less susceptible to voltage sags or spikes compared to conventional power supplies, and provides greater electromagnetic isolation and better protection against AC line noise.

Connect the power adapter connector of the Power Block to the FreePlay LIVE. Push the line cord securely into the Power Block and plug the other end into a grounded AC outlet.



Only use the factory-authorized power supply that came with the FreePlay LIVE.

2. Power Switch

Press the top of this rocker switch inwards to turn FreePlay LIVE on and press the bottom of this rocker switch inwards to turn FreePlay LIVE off.

When powered up, the meters on the top panel will illuminate for ten seconds to indicate the battery level. After ten seconds, the meters will display the output level.

3. XLR and 1/4" Combo Inputs

Both input channels may accept a balanced mic or line-level signal using an XLR connector. They are wired as follows, according to standards specified by the AES (Audio Engineering Society).

XLR Balanced Wiring:

- Pin 1 = Shield (ground)
- Pin 2 = Positive (+ or hot)
- Pin 3 = Negative (- or cold)

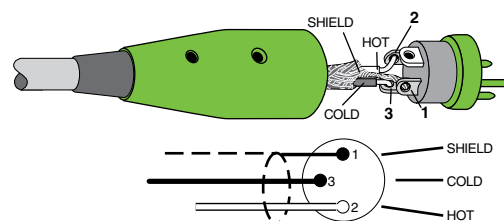

In addition to accepting balanced mic or line-level signals using an XLR connector, both channels may also accept 1/4" line-level signals driven by balanced or unbalanced sources.

Additionally, both channels may accept Hi-Z sources (such as guitars) via the 1/4" input without the need for a separate DI box.

To connect balanced lines to these inputs, use a 1/4" Tip-Ring-Sleeve (TRS) plug. "TRS" stands for Tip-Ring-Sleeve, the three connection points available on a stereo 1/4" or balanced phone jack or plug. TRS jacks and plugs are used for balanced signals and are wired as follows:

1/4" TRS Balanced Mono Wiring:

- Sleeve = Shield
- Tip = Hot (+)
- Ring = Cold (-)

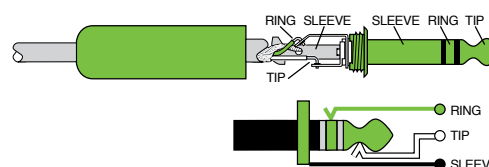

FreePlay LIVE: Rear Panel Features Continued...

To connect unbalanced lines to these inputs, use a 1/4" mono (TS) phone plug, wired as follows:

1/4" TS Unbalanced Mono Wiring:

Sleeve = Shield
Tip = Hot (+)

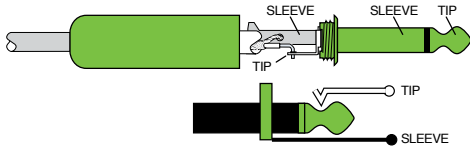

VERY IMPORTANT NEVER connect the output of an amplifier directly to a FreePlay LIVE's input jack. This could damage the input circuitry and we wouldn't want that now, would we?

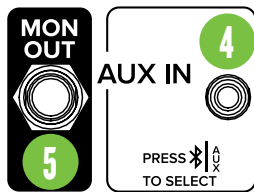

4. Bluetooth / Aux Input

The Bluetooth / Aux input may accept an 1/8" line-level or Bluetooth [stereo audio streaming] signal from a smartphone, MP3 player, or other signal source. The level may be raised or lowered via FreePlay LIVE's + and - buttons on the top panel or FreePlay Connect.



The Bluetooth may disconnect when affected by Electrostatic Discharge [ESD]. Manually reconnect the Bluetooth connection.



VERY IMPORTANT NEVER connect the output of an amplifier directly to a FreePlay LIVE's input jack. This could damage the input circuitry.



A Bluetooth connection and 1/8" line-level connection may NOT be used simultaneously. If there is a physical connection to the aux input, it will take priority over any Bluetooth connection. For example, if you are playing a song from a smartphone (connected via Bluetooth) and connect an MP3 player to the 1/8" jack, the smartphone song will be interrupted and the MP3 player now takes precedence.

5. Mon Out

This balanced 1/4" connector provides a mono-summed line-level output [i.e. copy of the main bus] that is designed for connecting a powered loudspeaker or subwoofer. It produces exactly the same signal that is connected to the input jack(s).

This signal is pre main fader, meaning that devices fed by the Mon out will NOT experience the same volume changes that FreePlay LIVE does (whether controlled from the hardware interface, or from the FreePlay Connect app.).



This signal, though, is post everything else, such as channel level, EQ, reverb, etc.

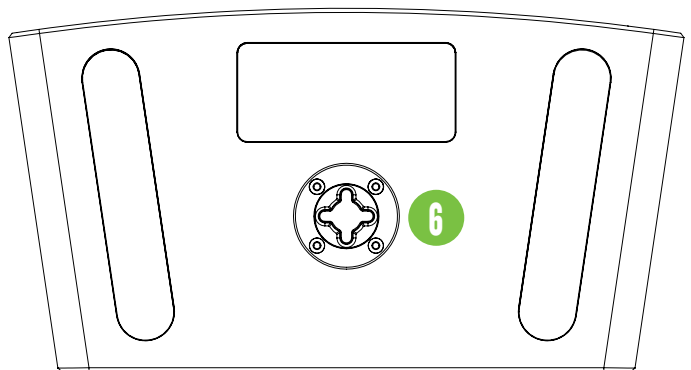

6. Pole Mount

Located on the bottom of the FreePlay LIVE is a hole for pole mounting on your favorite mic stand. Set it up outdoors for a BBQ and be sure to invite your neighbors over to join in on the fun!



VERY IMPORTANT Mounting the FreePlay LIVE on a mic stand requires the use of the included mic stand adapter.

FreePlay LIVE: Top Panel Features

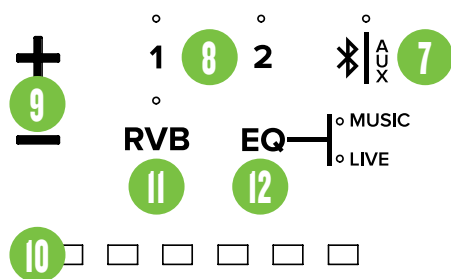

7. Bluetooth Button

Pairing and Connecting – Press and hold the Bluetooth button to select it. The LED located above the button will flash white when selected. This is to indicate that the FreePlay LIVE and device are in pairing mode.

While FreePlay LIVE is in pairing mode, simultaneously scan for Bluetooth devices on the smart phone or tablet. You should see FreePlay LIVE appear in the “available devices” list. Select it. From there, the device should indicate that it is successfully connected.



The Bluetooth may disconnect when affected by Electrostatic Discharge [ESD]. Manually reconnect the Bluetooth connection.

Level – Press the Bluetooth/Aux button to select it. The LED located above the button will illuminate white when selected. Be sure to raise or lower that channel's input level using the + and – level buttons. The input level will be represented in the meters with green LEDs. After five seconds of inactivity, the Bluetooth/Aux LED will turn off and the selection changes back to the main output [default].

8. Channel 1 and 2 Buttons

Press the Channel 1 or 2 button to select it. The LED located above the button will illuminate white when selected. Once a channel is selected, be sure to raise or lower that channel's input level using the + and – level buttons. The input level will be represented in the meters with green LEDs. After five seconds of inactivity, the channel LED will turn off and the selection changes back to the main output [default].



If you quickly press and release the channel 1 and 2 buttons simultaneously, the meters will indicate the battery strength before returning to display the output level.



If you press and hold the channel 1 and 2 buttons simultaneously for three seconds before releasing, the FreePlay Live is reset to its factory default. Please keep in mind that this erases all settings that may have been set. You are also wiping the FreePlay LIVE's memory of previously paired devices. To remedy this, you will need to ‘forget device’ in the Bluetooth settings of the device, then re-pair in order to regain communication and functionality.

9. Level [+ and –] Buttons

Push the + button repeatedly to add extra meat and veggies to your hoagie. Conversely, pushing the – button repeatedly will lower the amount of meat and veggies added to the grinder.

And now that lunch is over, a moment of truth. The + and – buttons actually adjust the selected input and overall output of the FreePlay LIVE from off to max.



The default selection is the output level. If another button is pressed, be sure to raise or lower the level within five seconds. After five seconds of inactivity, the selection changes back to the default output level.

10. Meters

This 6-segment meter illuminates green to display the input and output signal levels and battery strength.

The input level is easily changed by selecting the level you want to update followed by pushing the + and – buttons.

After five seconds of inactivity, the meters will reflect the output level.

11. RVB Button

Are you interested in adding some reverb to the signal? It's easy! Simply press the RVB button to turn it on and off. The LED located above the button will illuminate white when reverb is on.



This is a global reverb based on what reverb settings are currently saved on the FreePlay Connect App. Please refer to the FreePlay Connect App Reference Guide for additional details.

FreePlay LIVE: Top Panel Features Continued...

12. EQ Mode

Here you are able to change the FreePlay LIVE's EQ mode to tailor it to best suit your particular application.

On the FreePlay LIVE, there are two preset modes to choose from: Music and Live. Simply press the EQ button repeatedly until the EQ mode you want illuminates white.

Music EQ Mode – This mode bumps the lows and highs, perfect for music playback.

Live EQ Mode – This mode features a low frequency roll-off to get rid of unwanted thumps and adds boost and sparkle to mid-range and high frequencies.



Additionally, FreePlay LIVE features 3-band EQ per channel, accessible via the FreePlay Connect app. More information may be found in the FreePlay Connect Reference Guide.

Handle

We at Mackie understand that people like to get a handle on things. As such, a handle is located conveniently next to all of the top panel features so you can easily carry it to another room. Carry away, friend, we've got it handled.

Speaker Link

A really neat feature of the FreePlay is the ability to link it to an additional FreePlay. This way, you can either have a "stereo pair" in the same location or place one elsewhere to please guests in another room or outside (aka "zone mode"). It may link with any Mackie FreePlay model, not just the same one. Let's check out how to link them...

First, make sure that a device is connected to one of the two FreePlays via Bluetooth; directions on the previous page.

Next, press and hold the Bluetooth and + buttons *on the paired FreePlay* until the LED above the I button is solid white and the LED above the Bluetooth button starts flashing. This initiates speaker linking with the other FreePlay.

Linking to another FreePlay Live:

Press and hold the Bluetooth and – buttons on the FreePlay. The Bluetooth, Channel 1 (Primary / Master) and Channel 2 (Secondary / Slave) illuminate solid white, indicating success.

Linking to a FreePlay GO or FreePlay HOME:

Press and hold the speaker link button on the FreePlay GO / HOME until the LED illuminates solid white, indicating success.



The signal might cut out when linking. This is normal, as it allows the hardware to complete the linking process.

Factory Reset [aka Vulcan Mind Meld]

Since settings may be changed via FreePlay Connect, it may be necessary to reset the FreePlay LIVE to its factory settings.

Please keep in mind that this erases all settings, including any levels, EQs, etc. that may have been set. Be sure to power down any amps and/or powered speakers before resetting FreePlay LIVE.

Simply press and hold the Channel 1 and 2 buttons simultaneously to reset the FreePlay LIVE to its factory settings.



If you use the factory default key combination, you are also wiping the FreePlay's memory of previously paired devices. To remedy this, on your smartphone, tablet or other Bluetooth device, you will need to 'forget device' in the Bluetooth settings, then re-pair in order to regain communication and functionality.

AC Power

Be sure FreePlay LIVE is plugged into an outlet that is able to supply the correct voltage specified for your model. It will continue to operate at lower voltages, but will not reach full power.

Be sure the electrical service can supply enough amperage for all the components connected to it.

We recommend that a stiff (robust) supply of AC power be used because the amplifiers place high current demands on the AC line. The more power that is available on the line, the louder the speakers will play and the more peak output power will be available for a cleaner, punchier bass. A suspected problem of "poor bass performance" is often caused by a weak AC supply to the amplifiers.

Care and Maintenance

FreePlay LIVE will provide many years of reliable service if you follow these guidelines:

- Avoid exposing it to moisture. If it's set up outdoors, be sure it's under cover if rain is expected.
- Avoid exposure to extreme cold (below freezing temperatures). If you must operate FreePlay LIVE in a cold environment warm up the voice coils slowly by sending a low-level signal through them for about 15 minutes prior to high-power operation.
- Use a dry cloth to clean FreePlay LIVE. Only do this when the power is turned off. Avoid getting moisture into any of the openings.

Appendix A: Service Information

If you think your FreePlay LIVE has a problem, please check out the following troubleshooting tips and do your best to confirm the problem. Visit the Support section of our website (www.mackie.com/support) where you will find lots of useful information such as FAQs and other documentation. You may find the answer to the problem without having to part with your FreePlay LIVE.

Troubleshooting

No power

- Our favorite question: Is it plugged in? Make sure the included power adapter is securely fastened to both the FreePlay LIVE and AC outlet.
- Our next favorite question: Is the power switch on? If not, try turning it on.
- Are the meters on the top panel illuminated?
- Is the battery charged?

No sound

- Is the level of the input source turned all the way down? Verify that all the volume controls in the system are properly adjusted. Look at the level meter to ensure that the FreePlay LIVE is receiving a signal.
- Is the signal source working? Make sure the connecting cables are in good repair and securely connected at both ends. Make sure the output level control of the source is turned up sufficiently.
- Make sure the source(s) are not turned off or muted. If you find something like this, make sure the level is turned down before disengaging the offending switch.

Poor sound

- Is it loud and distorted? Make sure that you're not overdriving a stage in the signal chain. Verify that all level controls are set properly.
- Is the input connector plugged completely into the jack? Be sure all connections are secure.

Noise

- Make sure all connections to the FreePlay LIVE are good and sound.
- Make sure none of the cables are routed near AC cables, power transformers, or other EMI-inducing devices.
- Is there a light dimmer or other SCR-based device on the same AC circuit as the FreePlay? Use an AC line filter or plug the FreePlay into a different AC circuit.

Hum

- Try disconnecting the cable connected to the main input jack. If the noise disappears, it could be a "ground loop," rather than a problem with the FreePlay. Try some of the following troubleshooting ideas:
 - Use balanced connections throughout your system for the best noise rejection.
 - Whenever possible, plug all the audio equipment's line cords into outlets which share a common ground. The distance between the outlets and the common ground should be as short as possible.

Bluetooth Issues

- Please email or call Technical Support if you are having Bluetooth connection issues:
 - o mackie.com/support-contact
 - o 1-800-898-3211

Repair

For warranty service, refer to the warranty information on page I6.

Non-warranty service is available at a factory-authorized service center. To locate the nearest service center, visit www.mackie.com/support/service-locator. Service for FreePlays living outside the United States may be obtained through local dealers or distributors.

If you do not have access to our website, please call our Tech Support department at 1-800-898-3211 (normal business hours, Pacific Time), to explain the problem. They will tell you where the nearest factory-authorized service center is located in your area.

Appendix B: Technical Information

FreePlay LIVE Specifications

Acoustic Performance:

Frequency Response (-10 dB)	60 Hz - 20 kHz
Frequency Response (-3 dB)	77 Hz - 20 kHz
Max peak SPL	115 dB
Crossover Point	3.0 kHz
Dispersion	90°

Equalization

Low Shelving	±10 dB @ 250 Hz
Mid-Peaking	±10 dB @ 1.0 kHz
High Shelving	±10 dB @ 2.0 kHz
Increments	±1 dB

Low Frequency Section

Driver Diameter	6.0 in / 152 mm
Voice Coil Diameter	1.0 in / 25 mm
Cone Material	Treated Paper
Magnet Material	Ceramic

High Frequency Section

Voice Coil Diameter	1.0 in / 25 mm
Horn Entry Diameter	1.0 in / 25 mm
Diaphragm Material	Polyethylene Naphthalate (PEN)
Magnet Material	Ceramic

Power Amplifiers

System Power Amplification	
Rated Power	150 watts peak 75 watts rms
Rated THD	<1%
Cooling	Convection
Design	Class D

System Processing

Channel EQ	3-band
Main EQ	2 voicing modes
FX	Reverb

Input / Output

XLR	10 kΩ Balanced
1/4" TRS	100 kΩ Balanced
1/4" TS	400 kΩ Unbalanced
1/8"	10 kΩ Stereo
Monitor Output	1/4" TRS Balanced

Power

Power Requirements	100-240 VAC, 50/60 Hz, 1.5 Amps, 19 VDC, 3.42 Amps
Operating Temperature [extended ambient temperature]	0 to 40 °C 32 to 104 °F

Safety Features

Limiting / Protection	Input and system limiting and amplifier thermal protection
-----------------------	---

Battery Information

Battery Type	Lithium Ion
Capacity	2600 mAh / 37.44 Wh
Nominal Voltage	14.4 V DC
Operating Temperature Range	-20 to 60 °C
Charging Temperature Range	0 to 40 °C

Bluetooth Information

Bluetooth Protocol	4.2
Bluetooth Function	Audio Streaming and User Interface Control

Physical Properties

Height:	7.8 in / 198 mm
Width:	14.0 in / 356 mm
Depth:	7.0 in / 178 mm
Weight:	8.8 lb / 4.0 kg

Disclaimer

Since we are always striving to make our products better by incorporating new and improved materials, components, and manufacturing methods, we reserve the right to change these specifications at any time without notice.

The "Running Man" figure is a registered trademark of LOUD Audio, LLC.

All other brand names mentioned are trademarks or registered trademarks of their respective holders, and are hereby acknowledged.

©2018 LOUD Audio, LLC
All Rights Reserved.

FreePlay LIVE Dimensions

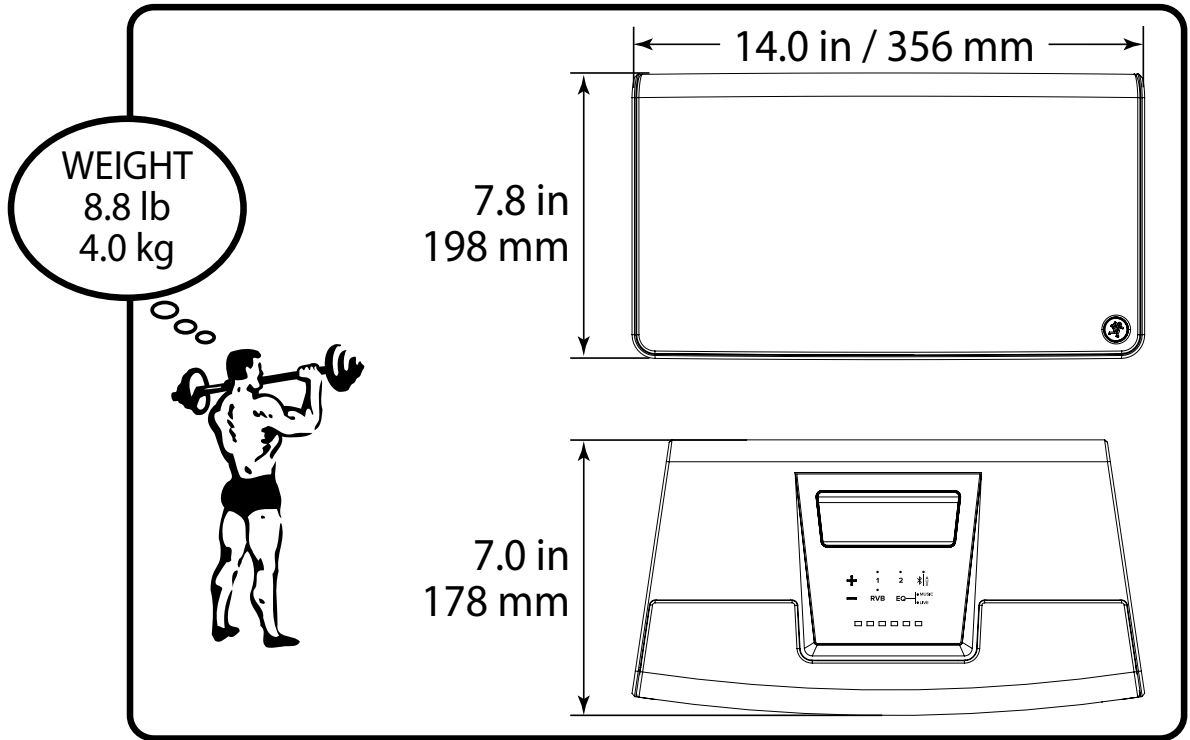

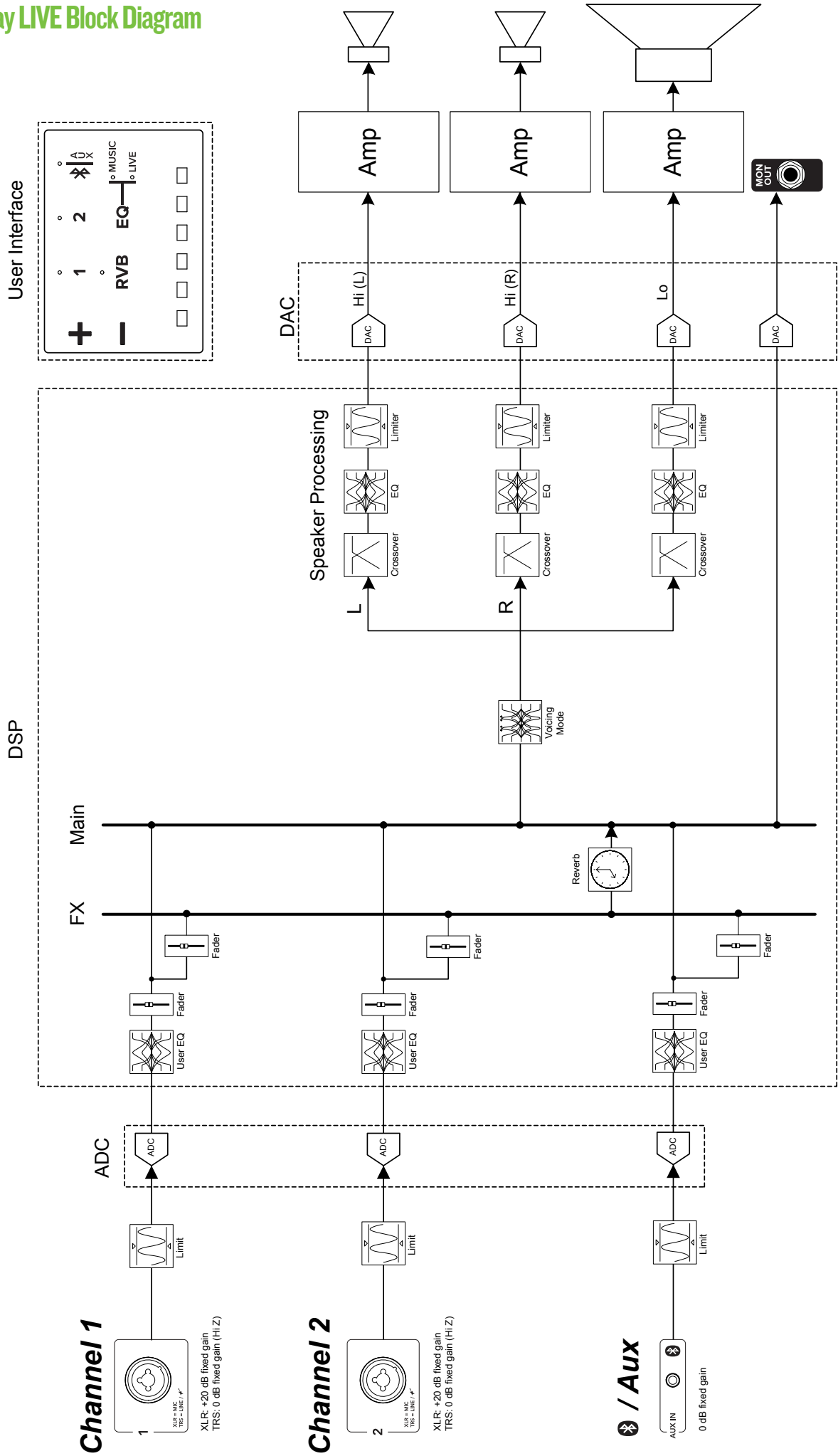

Please keep your sales receipt in a safe place.

This Limited Product Warranty (“Product Warranty”) is provided by LOUD Audio, LLC (“LOUD”) and is applicable to products purchased in the United States or Canada through a LOUD-authorized reseller or dealer. The Product Warranty will not extend to anyone other than the original purchaser of the product (hereinafter, “Customer,” “you” or “your”).

For products purchased outside the U.S. or Canada, please visit www.mackie.com to find contact information for your local distributor, and information on any warranty coverage provided by the distributor in your local market.

LOUD warrants to Customer that the product will be free from defects in materials and workmanship under normal use during the Warranty Period. If the product fails to conform to the warranty then LOUD or its authorized service representative will at its option, either repair or replace any such nonconforming product, provided that Customer gives notice of the noncompliance within the Warranty Period to the Company at: www.mackie.com or by calling LOUD technical support at 1.800.898.3211 (toll-free in the U.S. and Canada) during normal business hours Pacific Time, excluding weekends or LOUD holidays. Please retain the original dated sales receipt as evidence of the date of purchase. You will need it to obtain any warranty service.

For full terms and conditions, as well as the specific duration of the Warranty for this product, please visit www.mackie.com.

The Product Warranty, together with your invoice or receipt, and the terms and conditions located at www.mackie.com constitutes the entire agreement, and supersedes any and all prior agreements between LOUD and Customer related to the subject matter hereof. No amendment, modification or waiver of any of the provisions of this Product Warranty will be valid unless set forth in a written instrument signed by the party to be bound thereby.

Need help with the FreePlay LIVE?

- Visit www.mackie.com/support to find: FAQs, manuals, addendums, and other documents.
- Email us at: www.mackie.com/support-contact
- Telephone 1-800-898-3211 to speak with one of our splendid technical support chaps (Monday through Friday, normal business hours, Pacific Time).



**16220 Wood-Red Road NE
Woodinville, WA 98072 • USA
Phone: 425.487.4333
Toll-free: 800.898.3211
Fax: 425.487.4337
www.mackie.com**
