

# VOCAL PERFORMER

# VE-5

## Owner's Manual



\* **With the factory settings, the VE-5 will automatically be switched off 10 hours after you stop playing or operating the unit.**  
If you don't want the unit to turn off automatically, change the "Auto Off" setting to "Off" as described on "Auto Off Function" (p. 15).

## Main Features

### A wealth of vocal-use effects at your fingertips

- Comes with 30 different sounds geared specifically for vocals (up to 50 can be saved).
- The [FAVORITE SOUND] buttons let you quickly call up frequently used sounds.
- It's easy to access a diverse range of sounds—simply turn the knob!

### Easy operation is ideal for live performance

- Mic stand holder allows easy attachment to your mic stand.
- Built-in mic lets you perform anytime, anywhere.
- The [HARMONY] button lets you add realtime harmony effects to your performance.
- "Phrase Loop function" lets you layer your voice to easily create looped performances.

### Numerous high-quality effects

- "Reverb" and "Delay" add spaciousness and depth to your voice.
- "Double/Harmony" adds beautiful resonance and warmth to your voice.
- "Dynamics" makes the volume consistent, and "Pitch Correct" ensures accurate pitch.
- Use unique effects like "Distortion" or "Radio" to create distinctive performances.

Before using this unit, carefully read the sections entitled: "USING THE UNIT SAFELY" and "IMPORTANT NOTES" (supplied on a separate sheet). These sections provide important information concerning the proper operation of the unit.

Additionally, in order to feel assured that you have gained a good grasp of every feature provided by your new unit, Owner's manual should be read in its entirety. The manual should be saved and kept on hand as a convenient reference.

# Contents

---

<b>Main Features</b> .....	<b>1</b>
<b>Installing Batteries</b> .....	<b>3</b>
<b>Easy Quick Guide</b> .....	<b>4</b>
Sound List .....	<b>5</b>
Taking Advantage of the VE-5 .....	<b>6</b>
Using Phrase Loops .....	<b>8</b>
<b>Panel Descriptions</b> .....	<b>9</b>
<b>Connections</b> .....	<b>10</b>
Adjusting the Mic Input Sensitivity .....	<b>11</b>
Phantom Power Setting .....	<b>11</b>
Attaching the VE-5 to a Mic Stand .....	<b>12</b>
<b>Selecting Sounds</b> .....	<b>13</b>
Selecting Sounds .....	<b>13</b>
Storing a Favorite Sound .....	<b>13</b>
<b>Editing the Sound (Top Screen)</b> .....	<b>14</b>
Matching the Harmony to the Key of Your Song .....	<b>14</b>
Adjusting the Volume of the Harmony ...	<b>14</b>
Adjusting the Level of the Delay/Reverb Effect .....	<b>14</b>
Adjusting the Volume of the Sound .....	<b>14</b>
Adjusting the Volume of the Output .....	<b>14</b>

---

---

<b>Editing (Menu)</b> .....	<b>15</b>
<b>SETUP</b> (Settings for the VE-5) .....	<b>15</b>
Display Contrast .....	<b>15</b>
Auto Off Function .....	<b>15</b>
<b>CTL PEDAL</b> (External Foot Switch) .....	<b>15</b>
<b>PHRASE LOOP</b> .....	<b>15</b>
<b>MIC</b> (Settings for the Mic) .....	<b>15</b>
Mic Input Sensitivity .....	<b>15</b>
Low Frequency Cut .....	<b>16</b>
Phantom Power On/Off .....	<b>16</b>
Internal Mic On/Off .....	<b>16</b>
<b>DYNAMICS</b> .....	<b>16</b>
<b>PITCH CORRECT</b> .....	<b>16</b>
<b>TONE/SFX</b> .....	<b>16</b>
<b>DOUBLE/HARMONY</b> .....	<b>16</b>
<b>DELAY</b> .....	<b>17</b>
<b>REVERB</b> .....	<b>17</b>
<b>HARMONY BUTTON</b> (Setting of the [HARMONY] Button) .....	<b>17</b>
<b>MASTER</b> (Settings of the Sound) .....	<b>17</b>
<b>Naming/Copying a Sound</b> .....	<b>18</b>
<b>NAME</b> (Naming Your Sound) .....	<b>18</b>
<b>COPY TO</b> (Copying a Sound as a Different Sound) .....	<b>18</b>
<b>EXCHANGE</b> (Exchanging sounds) .....	<b>18</b>
<b>COPY PRESET</b> (Copying a Preset Sound) .....	<b>18</b>
<b>Restoring the Factory Settings</b> .....	<b>19</b>
<b>FACTORY RESET</b> (Restoring the Factory Settings) .....	<b>19</b>
<b>Troubleshooting</b> .....	<b>19</b>
<b>Specifications</b> .....	<b>20</b>

---

- It is forbidden by law to make an audio recording, video recording, copy or revision of a third party's copyrighted work (musical work, video work, broadcast, live performance, or other work), whether in whole or in part, and distribute, sell, lease, perform, or broadcast it without the permission of the copyright owner.

Do not use this product for purposes that could infringe on a copyright held by a third party. We assume no responsibility whatsoever with regard to any infringements of third-party copyrights arising through your use of this product.

- Roland and BOSS are either registered trademarks or trademarks of Roland Corporation in the United States and/or other countries.
- Company names and product names appearing in this document are registered trademarks or trademarks of their respective owners.
- MMP (Moore Microprocessor Portfolio) refers to a patent portfolio concerned with microprocessor architecture, which was developed by Technology Properties Limited (TPL). Roland has licensed this technology from the TPL Group.

Copyright © 2012 BOSS CORPORATION

All rights reserved. No part of this publication may be reproduced in any form without the written permission of BOSS CORPORATION.

# Installing Batteries

Insert the included batteries (AA x 4) as shown in the diagram, being careful to observe the correct polarity.

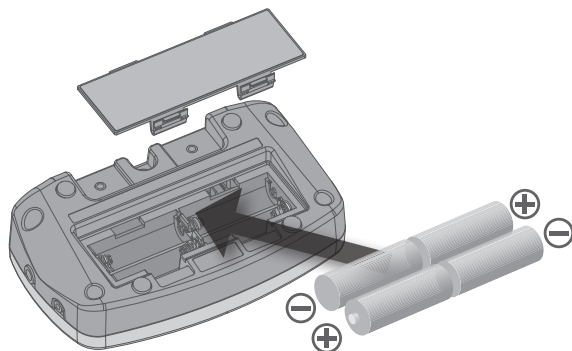

## WARNING

### Handle batteries carefully

- Batteries must never be recharged, heated, taken apart, or thrown into fire or water.
- Never expose batteries or rechargeable batteries to excessive heat such as sunshine, fire or the like.
- Incorrect handling of batteries, rechargeable batteries, or a battery charger can cause leakage, overheating, fire, or explosion. Before use, you must read and strictly observe all of the precautions that accompany the batteries, rechargeable batteries, or battery charger.
- When using rechargeable batteries and a charger, use only the combination of rechargeable batteries and charger specified by the battery manufacturer.
- If used improperly, batteries or rechargeable batteries may explode or leak and cause damage or injury. In the interest of safety, please read and observe the following precautions.
  - Carefully follow the installation instructions for batteries, and make sure you observe the correct polarity.
  - Avoid using new batteries together with used ones. In addition, avoid mixing different types of batteries.
  - Remove the batteries whenever the unit is to remain unused for an extended period of time.
  - Never keep batteries together with metallic objects such as ballpoint pens, necklaces, hairpins, etc.
  - Used batteries must be disposed of in compliance with whatever regulations for their safe disposal that may be observed in the region in which you live.

### Handle leaking batteries carefully

- If fluid has leaked from a battery, make sure not to touch it with your bare hands.
- If any of the leaking fluid gets into your eyes, the loss of vision may result. Do not rub your eyes; use clean water to flush them thoroughly. Then, promptly see a doctor.
- Burning of the skin or dermatitis may result if fluid has gotten onto your skin or clothing. Use clean water to flush affected areas thoroughly; then, promptly see a doctor.
- Using a soft cloth, carefully wipe any remaining fluid from the inside of the battery compartment. Then, install new batteries.

## Notes Concerning Batteries

- The life of the supplied batteries may be limited, since its primary purpose was to enable testing.
- The use of an AC adaptor is recommended as the unit's power consumption is relatively high. Should you prefer to use batteries, please use the rechargeable Ni-MH battery type or alkaline type.  
In particular, using phantom power (p. 11) will increase the power consumption, so you should use an AC adaptor in this case.
- When installing or replacing batteries, always turn this unit off and disconnect any other devices you may have connected. This way, you can prevent malfunction and damage.
- If operating this unit on batteries, please disconnect the AC adaptor from this unit.
- Even if batteries are installed, the unit will turn off if you connect or disconnect the power cord from the AC outlet while the unit is turned on, or if you connect or disconnect the AC adaptor from the unit. When this occurs, unsaved data may be lost. You must turn off the power before you connect or disconnect the power cord or AC adaptor.
- When turning the unit upside down, position stacks of magazines (or other materials) under the unit in such a way that they will support its four corners, thus preventing damage to the buttons, knobs, etc.

## Notes Concerning Internal Memory

- Please be aware that all data contained in the unit's memory may be lost when the unit is sent for repairs. Important data should always be written down on paper (when possible). During repairs, due care is taken to avoid the loss of data. However, in certain cases (such as when circuitry related to memory itself is out of order), we regret that it may not be possible to restore the data, and Roland assumes no liability concerning such loss of data.
- Please be aware that the contents of memory can be irretrievably lost as a result of a malfunction, or the improper operation of the unit. To protect yourself against the risk of losing important data, we recommend that important data should always be written down on paper.
- Unfortunately, it may be impossible to restore the contents of data that was stored in the unit's memory once it has been lost. Roland Corporation assumes no liability concerning such loss of data.

# VE-5 Easy Quick Guide

## 1

**Install Batteries** page 3 / **Connect an AC Adaptor** page 10

First, install batteries → “Installing Batteries” (p. 3)  
or, connect an AC adaptor (BOSS PSA series; sold separately) → “Connections” (p. 10)

## 2

**Connect your Mic and Mixer to the VE-5** page 10

Connect the VE-5 between your mic and mixer.

### Typical connection for a mic



### Connection when using the VE-5



### Phantom power setting

If you're using a condenser mic that requires phantom power, turn phantom power on as described on “Phantom Power Setting” (p. 11).



page 11

### Mic stand

You can attach the VE-5 to your mic stand.



page 12

### OK even if you don't have a mic

The VE-5 has an internal mic. The internal mic will be used if an external mic is not connected.

Internal Mic



### When connecting via line output

If you want to connect the VE-5 via its line output to your mixer, connect a commercially available Y-adaptor audio cable to the PHONES/LINE OUT jack.



### Headphones

page 10

Connect stereo headphones (sold separately) with a stereo mini-plug to the PHONES/LINE OUT jack.



## 3

**Turn the Power On**

Hold down the [⏻] button until the power turns on.



\* **Before you make connections, make sure that the input gain or volume of your mixer or recorder is turned down.** By turning on devices in the wrong order, you risk causing malfunction and/or damage to speakers and other devices.

## 4

## Sing

Go ahead and sing.

Use the [EFFECT] button to switch the effect on/off, and hear the difference it makes.



## Adjusting the volume

You can use the [VOLUME] dial to adjust the volume.

## If your voice sounds distorted

Adjust the input sensitivity as described on "Adjusting the Mic Input Sensitivity" (p. 11).

[VOLUME]

dial

## 5

## Select Sounds

page 13

Turn the [SOUND] knob to switch between different sounds.

On the VE-5, effect settings are organized as "sounds." You can apply the desired effect simply by selecting a sound.



## Sound List

## Effect sounds for specific musical styles

Sound	Explanation
1 BRIGHT ECHO	Pleasant echo
2 DEEP ECHO	Deep echo
3 ARENA	Simulates an enormous arena
4 CATHEDRAL	Deep and rich reverb
5 ENSEMBLE	Spacious ensemble sound
6 POP	For vocal definition
7 BALLAD	Ballad tone with reverb
8 ROCK	Rock sound also suitable for simple backing
9 JAZZ	Jazz club setting
10 HIP HOP	Processed vocal, lightly distorted
11 HARMONICA	Setting for harmonica; simulates amp distortion
12 SAXOPHONE	Setting for sax, with crisp reverb

## Harmony sound that adds a natural harmony / Double-tracking effects that add depth to your voice

Sound	Explanation
13 5th HARMONY	Parallel-fifth harmony, suitable for many styles
14 3rd HARMONY	Parallel-third harmony, emphasizing the feel of the song
15 DOUBLE VOICE	Double-tracking effect simulates two voices
16 FOUR VOICE	Double-tracking effect and delay simulate four voices
17 UNISON	Unison sound that adds depth to your vocal

## Sounds with automatic pitch correction

Sound	Explanation
18 PitchCorrect	Natural-sounding pitch correction in semitone steps
19 CHROMATIC	Chromatic voice sound, pitch-corrected in stepwise fashion
20 ROBOT	Cyber-robot voice
21 ElectricTune	Stepwise pitch correction in large steps

## Special-effect sounds such as radio voice or strobed voice

Sound	Explanation
22 DISTORTION	Vocal distortion
23 RADIO	Radio-voice sound ideal for instantly changing the atmosphere
24 STROBE	Rhythmic Rap setting
25 CHORUS	Chorus effect for vocal depth
26 FLANGER	Flanger effect that adds a sense of modulation
27 HEAVY SCREAM	Hardcore vocal
28 SPACE LOUNGE	Outer space announcer
29 OPERA QUEEN	Lustrous high voice
30 REFRAIN	Distinctive echoed voice

# Taking Advantage of the VE-5

# 1

## Adjusting the Spaciousness (Delay/Reverb)

page 14

Delay is an echo-like effect. Reverb is the sense of spaciousness and reverberation you can experience when singing in a room or hall. Here's how to adjust the depth of these effects.

1. Use the [◀] [▶] buttons to select "DlyLevel" or "RevLevel."
2. Turn the [SOUND] knob to adjust the delay/reverb level.



\* If you want to turn off, set Level to 0.

3. Press the [EXIT] button to return to the top screen.

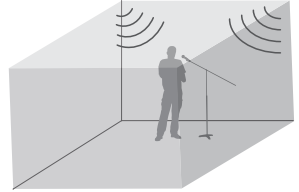

# 2

## Using Harmony

page 14

"Harmony" lets you add a natural-sounding harmony part to your own voice.

### Turning the Harmony on/off

To apply the harmony effect, press the [HARMONY] button so it's lit.

Factory preset sounds no. 13–14 were created for use with harmony. Let's try out the harmony effect.



### Matching the harmony to the key of your song

Specify the key of the song you're singing. For example, choose "C" if the song is in C-major, or "Am" if the song is in A-minor.

**The notes generated by harmony or pitch correction (p. 16) will be based on the key you specify here, so be sure to specify the correct key.**

1. Use the [◀] [▶] buttons to select "Key."
2. Turn the [SOUND] knob to set the key.



3. Press the [EXIT] button to return to the top screen.

How the key of the song corresponds with the key signature (#, b)

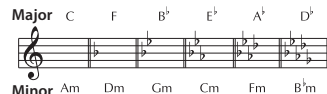

### Adjusting the volume of the harmony

The VE-5 lets you layer a harmony part onto your own voice. Here's how to adjust the volume of the harmony part.

1. Use the [◀] [▶] buttons to select "HrmLevel."
2. Turn the [SOUND] knob to adjust the volume of the harmony.

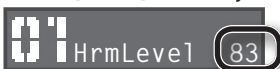

3. Press the [EXIT] button to return to the top screen.

You can edit the VE-5's parameters to adjust the sound in detail. Here we'll explain some advanced techniques, starting from the factory-set sounds.

**For details on the procedure, refer to "Editing procedure in the menu" (p. 15).**

## Changing third harmony into fourth harmony

Harmony is typically at intervals of a third or fifth, but you can make your song musically richer by adding harmony at a fourth or sixth. By editing the DOUBLE/HARMONY parameter "Type," you can add harmony at intervals of a fourth or sixth.

1. Select the "14 3rd HARMONY" sound.
2. Specify the key of the song (p. 6).
3. Change the "DOUBLE/HARMONY" menu parameter "Type" from "+3rd" to "+4th."

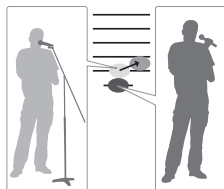

## Switching the gender of the harmony voice between male/female

DOUBLE/HARMONY provides a unique parameter named "Gender," allowing you to switch the character of the harmony voice between male and female.

1. Select the "14 3rd HARMONY" sound.
2. Specify the key of the song (p. 6).
3. Edit the "DOUBLE/HARMONY" menu parameter "Gender."

Negative (-) settings give the voice a more masculine character, while positive (+) settings make the voice more feminine.



## Switching your voice between male/female

If you want to switch the characteristics of your own voice between masculine and feminine, edit the PITCH CORRECT "Gender" parameter.

1. Select the "18 PitchCorrect" sound.
2. Edit the "PITCH CORRECT" menu parameter "Gender."

Negative (-) settings give the voice a more masculine character, while positive (+) settings make the voice more feminine.

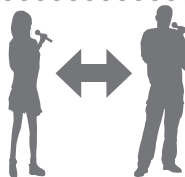

## Using a pitch-corrected electronic sound

Here's how to get a mechanistic sound in which the pitch changes in steps (recently popular in pop music). To make this effect more convincing, specify the key of the song so that the pitch is corrected to that key.

1. Select the "21 ElectricTune" sound.
2. Specify the key of the song (p. 6).
3. Change the "PITCH CORRECT" menu parameter "Scale" from "Chromatic" to "Maj (Min)."

Now the pitch will be corrected to fit the scale of the song's key. When singing, try to avoid applying delicate vibrato; use your voice to describe fairly large curves when changing pitch.

You can also produce an electrical feel by adjusting the "Gender" parameter mentioned above.

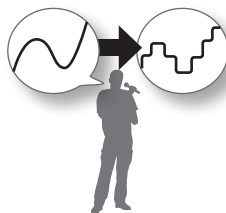

### How do I get back to the factory-set sound?

The sound settings will automatically be saved when you press the [EXIT] button to return to the top screen.

If you want to return a sound to its factory settings, refer to "COPY PRESET (Copying a Preset Sound)" (p. 18).

If you want to return all sounds to their factory settings, refer to "Restoring the Factory Settings" (p. 19).

# Using Phrase Loops

You can use the [LOOP] button to layer sounds while carrying out recording and playback. By layering different melody lines you can simulate an a cappella chorus by yourself, or use voice percussion to add rhythm phrases to your performance.

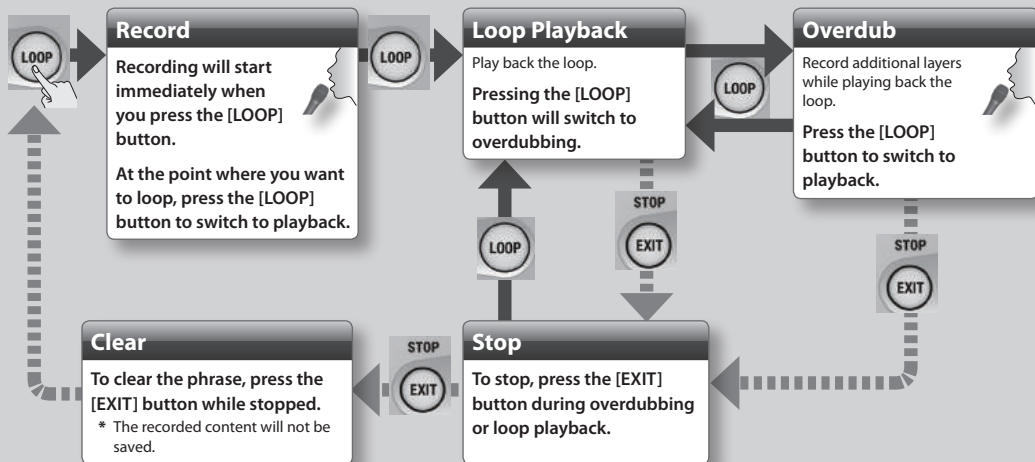

## [LOOP] button color

Display	Status
Red	Recording
Green	Playback
Yellow	Overdub
Green (blink)	Stopped (phrase exists)
Unlit	Stopped (no phrase)

## MEMO

- \* The recording time is 38 seconds.
- \* Sound from the AUX IN jack will not be recorded.
- \* The recorded content will be lost when you turn off the power.

## Sound Check Function

You can record your voice before it is processed by the effect, and then while playing back the recording of your voice, you can apply an effect to hear how it sounds. This is a convenient way to edit the sound.

In "PHRASE LOOP" (p. 15), set the "LoopType" to "Check" **page 15**

- \* If you select the "Check" setting, you won't be able to overdub phrases. Choose the "Perform" setting if you want to overdub.

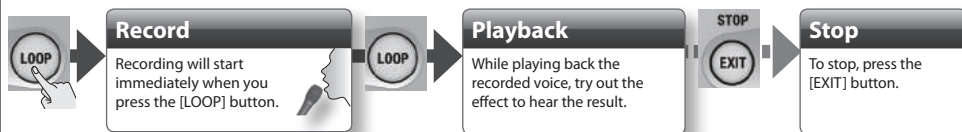



# Panel Descriptions

## [POWER] Button

This turns the power on/off. Hold down the button until the power turns on/off.

- \* This unit is equipped with a protection circuit. A brief interval (a few seconds) after turning the unit on is required before it will operate normally.
- \* Before turning the unit on/off, always be sure to turn the volume down. Even with the volume turned down, you might hear some sound when switching the unit on/off. However, this is normal and does not indicate a malfunction.

## Internal Mic

This is the internal mic. It will operate only if no mic is connected to the MIC IN jack. If desired, you can set the internal mic to stay off. For details, refer to "Internal Mic On/Off" (p. 16).

- \* Acoustic feedback (howling) might occur depending on the position of the speakers. If this occurs, take the steps described in "Note Concerning Howling" (p. 11).

## [MENU] Button

Edit the sound and make overall settings for the VE-5.

page 15

## [SOUND] Knob

In the top screen, this knob selects a sound. In the edit screens, this knob adjusts the value.

## Cursor Buttons

Use these to switch between parameters or to move the cursor.

## [EXIT] Button

Use this to return to the top screen.

## [LOOP] Button

page 8

This starts "phrase loop," allowing you to overdub your voice.

## [FAVORITE SOUND] Buttons

You can assign your favorite sounds to these buttons, and use the buttons to call up those sounds.

page 13

## [EFFECT] Button

This turns the effect on/off.

## [HARMONY] Button

page 6

This turns harmony on/off. This button can also turn on/off an effect other than harmony (p. 17).

## [VOLUME] Dial (Side Panel)

This adjusts the volume.

## Display

The top screen shows the sound number and name. The editing screens show parameters and their values.

- \* Never strike or apply strong pressure to the display.
- \* The explanations in this manual include illustrations that depict what should typically be shown by the display.

Note, however, that your unit may incorporate a newer, enhanced version of the system (e.g., includes newer sounds), so what you actually see in the display may not always match what appears in the manual.



# Connections

## DC IN Jack

This jack is for connecting an AC adaptor (BOSS PSA series; sold separately).

- \* Use only the specified AC adaptor (PSA series), and connect it to an AC outlet of the correct voltage. Do not use any other AC adaptor, since this may cause malfunction.



## XLR OUT Jack

Connect this to your mixer or recorder. It provides a balanced output of the VE-5's sound.

- \* This instrument is equipped with balanced (XLR) type jacks. Wiring diagrams for these jacks are shown as the illustration. Make connections after first checking the wiring diagrams of other equipment you intend to connect.

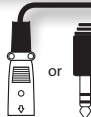
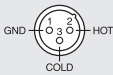

## PHONES/LINE OUT Jack

Headphones with a stereo mini-plug (sold separately) can be connected here.

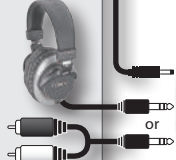

### LINE Output

If you want to connect the VE-5 via its line output to your mixer, connect a commercially available Y-adaptor audio cable to the PHONES/LINE OUT jack.



## AUX IN Jack

If you use a cord with a stereo mini-plug to connect a audio player or similar device, the sound of the connected device will be heard through this unit.

- \* Use the controls of the connected device (audio player) to adjust the volume.



## CTL 1, 2 Jack (Connecting a Foot Switch)

Connect foot switches (FS-5U, FS-6; sold separately). For details, refer to "CTL PEDAL (External Foot Switch)" (p. 15).

### When Connecting an FS-5U

Cable:  
1/4" phone type ↔  
1/4" phone type

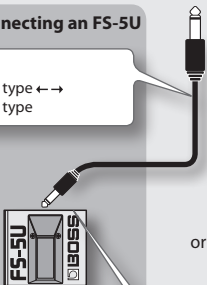

### When Connecting Two FS-5Us

Cable:  
Stereo 1/4" phone type ↔  
1/4" phone type x 2

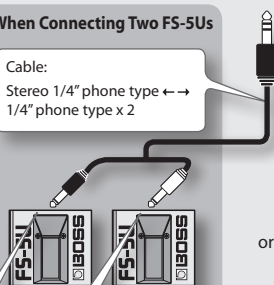

### When Connecting an FS-6

Cable:  
Stereo 1/4" phone type ↔  
Stereo 1/4" phone type

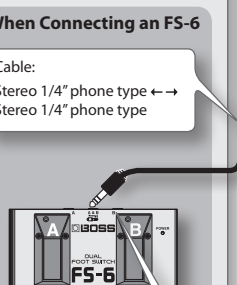

### POLARITY switch

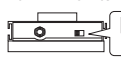

### MODE/POLARITY switch

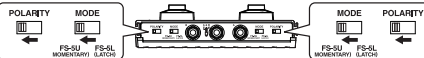

## MIC IN Jack

Connect a mic (sold separately).

- \* This instrument is equipped with balanced (XLR/TRS) type jacks. Wiring diagrams for these jacks are shown as the illustration. Make connections after first checking the wiring diagrams of other equipment you intend to connect.

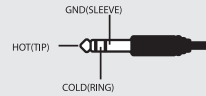

- \* **Do not connect the output of an effects processor or similar device to the MIC IN jack.** The sound may be distorted, and you may not obtain the desired effect.

## Adjusting the Mic Input Sensitivity

In order to use the VE-5 optimally, you'll need to adjust the input sensitivity.

1. Press the [MENU] button.
2. Use the [▶] button to select "MicSens."
3. Turn the [SOUND] knob to adjust MicSens.

At the ideal setting, the meter will occasionally reach the far right (as shown below) when you sing loudly.



- \* If your voice sounds distorted, lower the MicSens setting.

4. Press the [EXIT] button to return to the top screen.

## Note Concerning Howling

- \* Howling could be produced depending on the location of microphones relative to speakers. This can be remedied by:
  - Changing the orientation of the microphone(s).
  - Relocating microphone(s) at a greater distance from speakers.
  - Lowering volume levels.

## Phantom Power Setting

If you're using a condenser mic that requires phantom power, turn phantom power on as described below.

1. Press the [MENU] button.
2. Use the [▶] button to select "PhantomPower."
3. Turn the [SOUND] knob to select "On."

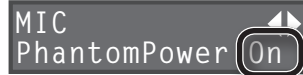

4. Press the [EXIT] button to return to the top screen.

- \* **WARNING: Precautions concerning use of phantom power supply**



**Always turn the phantom power off when connecting any device other than condenser microphones that require phantom power.**

You risk causing damage if you mistakenly supply phantom power to dynamic microphones, audio playback devices, or other devices that don't require such power. Be sure to check the specifications of any microphone you intend to use by referring to the manual that came with it. (This instrument's phantom power: 48 V DC, 10 mA Max)

## Note Concerning Connections

- \* To prevent malfunction and equipment failure, always turn down the volume, and turn off all the units before making any connections.

## Notes Concerning Live Performances

- \* If you're performing at a live event where someone other than yourself is responsible for running the sound system, it's a good idea to inform them that you intend to use an in-line effects processor (the VE-5) on your mic. This will allow them to make sure that necessary equipment such as connection cables are available, and will help the rehearsal and the actual performance go smoothly.
- \* Numerous types of PA equipment are used in a live event. Unexpectedly breaking a connection can produce high-volume noise, and may even damage equipment. Before you turn the VE-5's power on/off, or connect or disconnect the cables, be sure to check with a staff member and obtain their permission.

# Attaching the VE-5 to a Mic Stand

The VE-5 can be attached to a mic stand using the mic stand holder.

## WARNING

- \* **Be sure to follow the instructions in the Owner's Manual carefully when placing this unit on a stand. If it is not set up properly, you risk creating an unstable situation which could lead to the unit falling or the stand toppling, and may result in injury.**
- \* **When attaching the VE-5, take care not to drop it.**
- \* When using mic stands to support this unit, do not place them at unstable or inclined locations. You must place the stand on a stable and horizontal surface.
- \* After mounting the VE-5 on a mic stand, be sure to verify that it does not wobble.
- \* Make sure to appropriately manage the cables connected to the VE-5 so as to prevent accidents, such as might be caused by someone tripping over them.
- \* Even if you observe the cautions given in the owner's manual, certain types of handling may allow this product to fall from the stand, or cause the stand to overturn. Please be mindful of any safety issues before using this product.
- \* Take care not to pinch your finger in the mic stand holder.
- \* To prevent accidental ingestion of the parts below, always keep them out of the reach of small children.

Included Parts: Screws

Removable Parts: Washers of the mic stand holder

### 1. Attach the mic stand holder to the VE-5 as shown in the illustration.

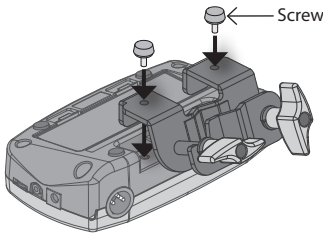

### 2. Loosen the two screws of the mic stand holder, and open the holder.

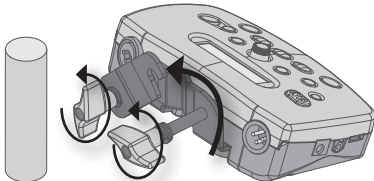

### 3. Return the holder to its original position so that it captures the mic stand, and tighten the two screws to secure the VE-5.

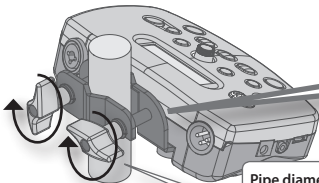

Pipe diameter of mic stands to which the VE-5 can be attached:  
14–28 mm (9/16–1-1/8 inches)

### Caution regarding attachment location

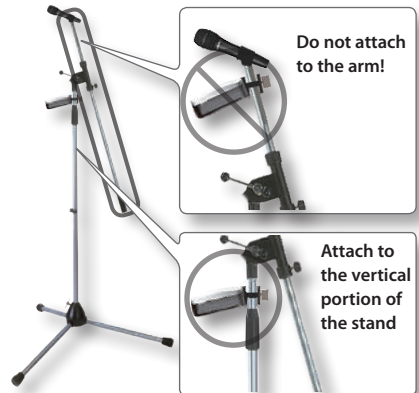

- \* When attaching the VE-5 to a mic stand, it's a good idea to use the included cable tie to fasten the cable to the stand.

- \* **Make sure the mic holders becomes parallel.**

- \* **Make sure the washers are positioned as the left figure.**

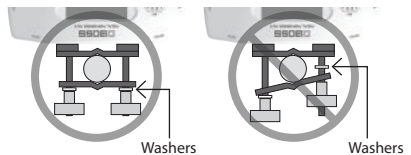

# Selecting Sounds

## What is an “effect”?

An “effect” modifies a specific component of a sound: volume, tone, pitch, or ambience. The VE-5 contains six different effects. Each can be switched on/off independently and various parameters can be adjusted. For details on how to edit an effect, refer to “Editing (Menu)” (p. 15).

Effects	Explanation
DYNAMICS	Makes the volume more consistent. This is a standard effect often used on vocals.
PITCH CORRECT	Corrects inaccuracies in the pitch. A broad range of effect types are provided, ranging from subtle pitch correction used in recording, or mechanical-sounding stepwise pitch change used in pop music.
TONE/SFX	“Tone” lets you use an equalizer to adjust the tone quality. “SFX” lets you apply special effects such as robot voice or strobe, which slices the sound at brief intervals.
DOUBLE/HARMONY	“Double” reproduces a technique in which the same person records the identical melody twice to layer the sound, giving it additional depth. “Harmony” lets you add a natural-sounding harmony part.
DELAY	Produces an echo-like effect.
REVERB	Produces the spacious reverberation that is typical of a performance in a room or hall.

## What is a “sound”?

On the VE-5, effect settings are organized as “sounds.” You can store up to 50 sounds. When the VE-5 is shipped from the factory, numbers 01–30 contain thirty types of sounds suitable for vocals. You can instantly obtain an effect simply by selecting one of these sounds.

## Selecting Sounds

1. In the top screen, turn the [SOUND] knob to select a sound.



## Storing a Favorite Sound

You can store your favorite sounds at the FAVORITE SOUND [A]–[C] buttons so that they can be called up instantly.



### Storing

1. Select the sound that you want to store.
2. Hold down the button (one of the buttons [A]–[C]) in which you want to store the selected sound, until the screen indicates “STORED!”

### Calling up sounds

3. Press one of the buttons from [A] through [C] to call up the sound you stored at that button.

# Editing the Sound (Top Screen)

## Editing procedure in the top screen



In the top screen you can make quick edits to the key of the harmony and to the depth of the delay/reverb.

The same procedure is used for all edits in the top screen.

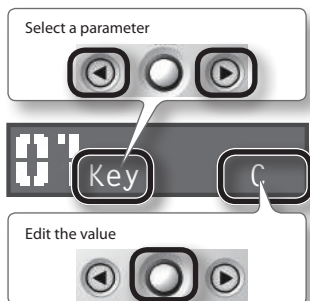
1. In the top screen, use the [◀] [▶] buttons to select a parameter, and turn the [SOUND] knob to edit the value of that parameter.



2. Press the [EXIT] button to return to the top screen.

Parameter	Explanation
<b>Matching the Harmony to the Key of Your Song</b>	
Key	Specify the key of the song you're singing. For example, choose "C" if the song is in C-major, or "Am" if the song is in A-minor.
	The notes generated by harmony or pitch correction (p. 16) will be based on the key you specify here, so be sure to specify the correct key.
	<b>How the key of the song corresponds with the key signature (#, b)</b>
	<p><b>Major</b> C F B<sup>b</sup> E<sup>b</sup> A<sup>b</sup> D<sup>b</sup></p>  <p><b>Minor</b> Am Dm Gm Cm Fm B<sup>b</sup>m</p> <p><b>Major</b> C G D A E B F<sup>#</sup></p>  <p><b>Minor</b> Am Em Bm F<sup>#</sup>m C<sup>#</sup>m G<sup>#</sup>m D<sup>#</sup>m</p>
The key you specify here will be the common value for the effects in the sound (harmony and pitch correction).	
<b>Adjusting the Volume of the Harmony</b>	
HrmLevel	The VE-5 lets you layer a harmony part onto your own voice. Here's how to adjust the volume of the harmony part.
<b>Adjusting the Level of the Delay/Reverb Effect</b>	
DlyLevel	Adjusts the level of the delay effect. If you want to turn off the delay effect, set to 0.
RevLevel	Adjusts the level of the reverb effect. If you want to turn off the reverb effect, set to 0.
<b>Adjusting the Volume of the Sound</b>	
MstLevel	Adjusts the volume of the sound.
<b>Adjusting the Volume of the Output</b>	
Volume	Displays the value of the [VOLUME] dial. This value can also be change with the [SOUND] knob.

## Saving the sound

The sound settings will automatically be saved when you press the [EXIT] button to return to the top screen.

If you don't want to save the changes you made (i.e., if you want to revert to the original sound), hold down the [▶] button and press the [EXIT] button.

# Editing (Menu)

## Editing procedure in the menu

The same procedure is used for all edits in the menu.

1. Press the [MENU] button.
2. Turn the [SOUND] knob to select a menu item, and press the [▶] button to confirm your selection.

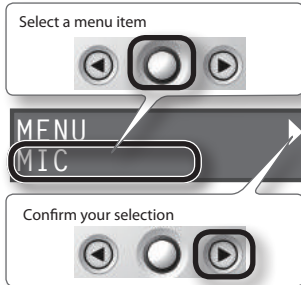

3. Use the [◀] [▶] buttons to select a parameter, and turn the [SOUND] knob to edit the value of that parameter.

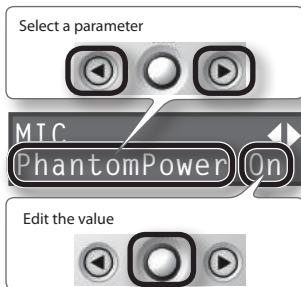

4. Press the [EXIT] button to return to the top screen.

\* To access the **SETUP**, **CTL PEDAL** and **PHRASE LOOP**, press the [MENU] button and then turn the [SOUND] knob to the left.

\* In **SETUP**, **CTL PEDAL**, **PHRASE LOOP** and **MIC** you can make overall (SYSTEM) settings that apply to the entire VE-5. Even if you switch sounds, these settings will not change.

## SETUP (Settings for the VE-5)

Here you can specify the functions of the display and Auto Off.

Parameter	Explanation
<b>Display Contrast</b>	
Contrast (default: 5)	Adjusts the display contrast (legibility).
<b>Auto Off Function</b>	
Auto Off (default: On)	With the factory settings, the VE-5 will automatically be switched off 10 hours after you stop playing or operating the unit. If you don't want the unit to turn off automatically, change this setting to "Off."

## CTL PEDAL (External Foot Switch)

Here you can specify the functions of the foot switches (p. 10) connected to the CTL 1, 2 jacks.

Parameter	Explanation	
Ctl1 (default: HRM On/Off)	EFX On/Off	Effect on/off
	HRM On/Off	Same operation as the [HARMONY] button
	SOUND Inc	Selects the next sound
Ctl2 (default: EFX On/Off)	SOUND Dec	Selects the previous sound
	FAV Inc	Selects the next favorite sound
	FAV Dec	Selects the previous favorite sound
	Loop Play	Same operation as the [LOOP] button
	Loop Stop	Same operation as the [LOOP] [STOP] button

## PHRASE LOOP

Here you can specify the type of the phrase loop (p. 8).

Parameter	Explanation	
LoopType (default: Perform)	Perform	The sound processed by the effect will be recorded and overdubbed (p. 8).
	Check	The sound unprocessed by the effect will be recorded, and the effect will be applied when the loop plays back (Sound Check: p. 8).

## MIC (Settings for the Mic)

Here you can make settings for the mic.

Parameter	Explanation
<b>Mic Input Sensitivity</b>	
MicSens (default: 40)	Adjusts the input sensitivity of the mic (p. 11).

## Editing (Menu)

Parameter	Explanation
<b>Low Frequency Cut</b>	
<b>LowCut</b> (default: Off)	Turn this on if you want to cut the unwanted low-frequency region.
<b>Phantom Power On/Off</b>	
<b>PhantomPower</b> (default: Off)	Turns the phantom power on/off (p. 11).
<b>Internal Mic On/Off</b>	
<b>IntMic</b> (default: On (Auto))	Turns the internal mic on/off. Even if this is "On (Auto)," the internal mic will be off if a mic is connected to the MIC IN jack.

## DYNAMICS

Makes the volume more consistent. This is a standard effect often used on vocals.

Parameter	Explanation
<b>On/Off</b>	Switches DYNAMICS on/off.
<b>Depth</b>	Adjusts the depth of DYNAMICS.
<b>Enhance</b>	Adjusts the depth of the Enhance effect. Higher settings will give the sound sharper definition.

## PITCH CORRECT

Corrects inaccuracies in the pitch. A broad range of effect types are provided, ranging from subtle pitch correction used in recording, or mechanical-sounding stepwise pitch change used in pop music.

Parameter	Explanation	
<b>On/Off</b>	Switches PITCH CORRECT on/off.	
<b>Type</b>	Soft	The pitch will be corrected smoothly.
	Hard	The pitch will be corrected quickly.
	Electric 1	Corrects pitch variation to a stair-step change.
	Electric 2	Applies stronger correction than Electric 1. This reproduces the mechanical-sounding stepwise pitch change used in pop music.
	Robot	Corrects the pitch to the specified note (Robot Voice).
<b>Scale</b>	Chromatic	The pitch is corrected to the nearest chromatic semitone.
	Maj (Min)	The pitch is corrected according to the Key setting.
<b>Key</b>	Specifies the key of the song when Scale is set to "Maj (Min)" (p. 14).	
<b>Note</b>	Specifies the pitch (fixed) when Type is set to "Robot."	

Parameter	Explanation
<b>Gender</b>	Negative (-) settings give the voice a more masculine character, while positive (+) settings make the voice more feminine.
<b>Octave</b>	Raise/drop the pitch by an octave.

## TONE/SFX

"Tone" lets you use an equalizer to adjust the tone quality. "SFX" lets you apply special effects such as robot voice or strobe, which slices the sound at brief intervals.

Parameter	Explanation	
<b>On/Off</b>	Switches TONE/SFX on/off.	
<b>Type</b>	PREAMP	Adjusts the tonal character by using the equalizer and the gain.
	DISTORTION	Produces a distorted voice.
	RADIO	Produces a radio voice.
	STROBE	Finely slices the voice.
	CHORUS	Adds richness to the voice.
	FLANGER	Adds a "swooshing" modulation.
<b>Gain *1</b>	Adjusts the level.	
<b>Bass *1</b>	Adjusts the tone quality of the low-frequency range.	
<b>Middle *1</b>	Adjusts the tone quality of the mid-frequency range.	
<b>Middle f *1</b>	Adjusts the frequency affected by the Middle parameter.	
<b>Treble *1</b>	Adjusts the tone quality of the high-frequency range.	
<b>Drive *2</b>	Adjusts the degree of distortion.	
<b>Tone *2</b>	Adjusts the tonal character.	
<b>Speed *3</b>	Specifies the speed.	
<b>Depth *4</b>	Adjusts the depth of CHORUS.	

\*1 Available if Type is set to PREAMP.

\*2 Available if Type is set to DISTORTION.

\*3 Available if Type is set to STROBE or FLANGER.

\*4 Available if Type is set to CHORUS.

## DOUBLE/HARMONY

"Double" reproduces a technique in which the same person records the identical melody twice to layer the sound, giving it additional depth.

"Harmony" lets you add a natural-sounding harmony part.

Parameter	Explanation
<b>On/Off</b>	Switches DOUBLE/HARMONY on/off.



Parameter	Explanation	
Type	Double	Produces a double-tracking effect.
	-1 - +1 oct	If you've specified the key of your song (p. 14), harmony that is suitable for that key will be added at the interval you specify here.
	Unison	By changing the vocal character, this produces the impression that another person is singing the same melody along with you.
Double	Adjusts the intensity of the Double effect in three levels (Light/Normal/Deep).	
HrmLevel *1	Adjusts the volume of the harmony part.	
Gender *1	Negative (-) settings give the voice a more masculine character, while positive (+) settings make the voice more feminine.	
Key *1	Specifies the key of the song you're singing (p. 14).	
DirectLevel *1	Adjusts the volume of the sound of the mic.	

\*1 Available if Type is set to -1 to +1 oct or Unison.

## DELAY

Produces an echo-like effect.

Parameter	Explanation	
On/Off	Switches DELAY on/off.	
Time	Adjusts the delay time (1–4000 ms).	
Feedback	Adjusts the amount of delayed sound that is repeated.	
DelayLevel	Adjusts the volume of the delayed sound.	

## REVERB

Produces the spacious reverberation that is typical of a performance in a room or hall.

Parameter	Explanation	
On/Off	Switches REVERB on/off.	
Type	Ambience	Produces a sense of spatial depth.
	Room	Produces warm reverberation.
	Hall 1	Produces clear and spacious reverberation.
	Hall 2	Produces mild and understated reverberation.
	Plate	Produces metallic-sounding reverberation with an extended high range.
Size	Adjusts the size of the room (space) to vary the reverb time.	
RevLevel	Adjusts the volume of the reverberation.	

## HARMONY BUTTON (Setting of the [HARMONY] Button)

You can use the [HARMONY] button to turn on/off effects other than Harmony.



Parameter	Explanation	
Type	DBL/HRM	The [HARMONY] button will turn the specified effect on/off.
	DELAY	
	PITCH	
	TONE/SFX	
	REVERB	
	DYNAMICS	
	CUSTOM	

## MASTER (Settings of the Sound)

Here you can make settings for the volume of the sound and the key of the song.

Parameter	Explanation	
Level	Specifies the volume of the sound.	
NoiseThres	Adjust this according to the noise level. Set this to a larger value if the noise level is high, or to a lower value if the noise level is low.	
Key	Specifies the key of the song you're singing (p. 14).	

# Naming/Copying a Sound

## NAME (Naming Your Sound)

To help you remember the tonality that a sound produces, you can assign a descriptive name of up to 12 characters to a sound.

1. Press the [MENU] button.
2. Turn the [SOUND] knob to select "NAME."

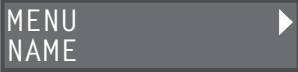

3. Press the [▶] button.
4. Use the [◀] [▶] buttons to select the character that you want to change, and turn the [SOUND] knob to choose the desired character.

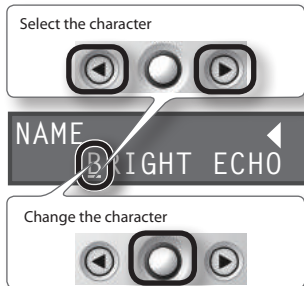

5. Press the [EXIT] button to return to the top screen.

## COPY TO (Copying a Sound as a Different Sound)

Here's how to copy the sound as a different sound.

1. Press the [MENU] button.
2. Turn the [SOUND] knob to select "COPY TO."



3. Press the [▶] button.

The [LOOP] button blinks, and the COPY TO screen appears.

4. Turn the [SOUND] knob to select the copy-destination sound.

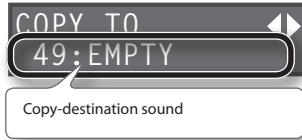

\* When you execute the Copy operation, the copy-destination sound will be lost.

If you decide not to execute the Copy operation, press the [EXIT] button to return to the previous screen.

5. Press the [LOOP] button.

The sound is copied.

\* Never turn off the power before the display indicates "COMPLETED!"

## EXCHANGE (Exchanging sounds)

You can change the order of the user sounds by exchanging them.

In step 3 of the COPY TO operation, press the [▶] button twice; the "EXCHANGE" screen will appear, allowing you to exchange the currently selected sound with the sound selected in the screen. The rest of the procedure is the same as for COPY TO.

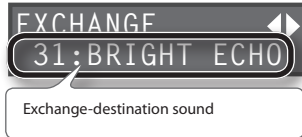

## COPY PRESET (Copying a Preset Sound)

You can copy a factory-set (preset) sound to the currently selected sound.

In step 3 of the COPY TO operation, press the [▶] button three times; the "COPY PRESET" screen will appear, allowing you to copy a preset sound to the currently selected sound. The rest of the procedure is the same as for COPY TO.



# Restoring the Factory Settings

## FACTORY RESET (Restoring the Factory Settings)

Here's how to restore the VE-5's settings to their factory-set condition.

\* When you execute "Factory Reset," the settings you made will be lost.

1. Press the [MENU] button.
2. Turn the [SOUND] knob to select "FACTORY RESET."



3. Press the [▶] button.

The [LOOP] button blinks, and the FACTORY RESET screen appears.

4. Turn the [SOUND] knob to specify the extent of the factory reset.

Value	Data to be initialized
ALL	All settings
SOUND	Settings for all sounds
SYSTEM	Settings of the SETUP, MIC, CTL PEDAL and PHRASE LOOP

If you decide not to execute the Factory Reset, press the [EXIT] button to return to the previous screen.

5. Press the [LOOP] button.

The settings you specified will return to their factory-set state.

\* Never turn off the power before the display indicates "COMPLETED!"

## Troubleshooting

Problem	Cause	Action
Power doesn't come on	Have the batteries run down?	Replace them with new batteries (p. 3). * The batteries included with the VE-5 are meant only to confirm that the unit is functional at the factory.
	Is the specified AC adaptor (PSA series; sold separately) connected correctly?	Check the connections again (p. 10). Never use any AC adaptor other than the adaptor specified.
No sound/volume is low	Is the other equipment connected correctly?	Check the connections again (p. 10).
	Could the volume or input gain of the connected mixer or recorder be lowered?	Check the settings of the connected device.
	Could the "Phantom Power" parameter be set to "Off?"	If you're using a condenser mic that requires phantom power, set the "Phantom Power" parameter to the On (p. 11).
Sound is distorted	Could the "MicSens" setting be too low?	Adjust the setting appropriately (p. 11).
	Is the "MicSens" setting appropriate?	Adjust the setting appropriately (p. 11).
	Is the output from another effects processor connected to the MIC IN jack?	Connect your mic directly to the MIC IN jack.
Can't store the recorded phrase	It is not possible to store a recorded phrase in the VE-5.	
Can't overdub using Phrase Loop	Could the "Loop Type" parameter be set to "Check?"	Overdubbing is not possible if this is set to "Check." If you want to overdub, set the "Loop Type" parameter to "Perform" (p. 15).

# Specifications

## BOSS VE-5: Vocal Performer

Nominal Input Level	MIC IN: -40 dBu (MicSens = 40)
	AUX IN: -20 dBu
Input Impedance	MIC IN: 4 k ohms
	AUX IN: 22 k ohms
Nominal Output Level	XLR OUT: -40 dBu
	PHONES/LINE OUT: -20 dBu
Output Impedance	XLR OUT: 600 ohms
	PHONES/LINE OUT: 33 ohms
Memory	Sound: 50
Effect Types	DYNAMICS, PITCH CORRECT, TONE/SFX, DOUBLE/HARMONY, DELAY, REVERB
Phrase Loop	38 sec. (Mono only)
Display	16 characters, 2 lines (backlit LCD)
Connectors	MIC IN jack (XLR type (balanced, phantom power: DC 48 V, 10 mA Max), 1/4 inch TRS phone type (balanced))
	AUX IN jack (Stereo miniature phone type)
	XLR OUT jack (XLR type)
	PHONES/LINE OUT jack (Stereo miniature phone type)
	CTL 1, 2 jack (1/4" TRS phone type)
Power Supply	DC IN jack
	Rechargeable Ni-MH Battery (AA, HR6) or Alkaline (AA, LR6) x 4, AC Adaptor (PSA series: sold separately)
Current Draw	190 mA (9 V max.)
Expected battery life under continuous use	Rechargeable Ni-MH battery (AA, HR6): Approx. 20 hours (phantom power: OFF) Approx. 9 hours (phantom power: ON)
	Alkaline (AA, LR6) : Approx. 13 hours (phantom power: OFF) Approx. 6 hours (phantom power: ON)  * These figures will vary depending on the specifications of the batteries and the actual conditions of use.
Dimensions	178 (W) x 108 (D) x 55 (H) mm 7-1/16 (W) x 4-1/4 (D) x 2-3/16 (H) inches
	178 (W) x 159 (D) x 55 (H) mm (including mic stand holder) 7-1/16 (W) x 6-5/16 (D) x 2-3/16 (H) inches
Weight	460 g / 1 lb 1 oz (including batteries)
	700 g / 1 lb 9 oz (including batteries and mic stand holder)
Accessories	Owner's Manual
	Leaflet (USING THE UNIT SAFELY, IMPORTANT NOTES, and Information)
	Mic Stand Holder (Screw x 2) * Pipe diameter of mic stands to which the VE-5 can be attached: 14–28 mm (9/16–1-1/8 inches)
	Audio Cable (Stereo Miniature Phone Type, Cable Tie Attached)
	Alkaline Battery (AA, LR6) x 4
Option (sold separately)	AC Adaptor (PSA series)
	Footswitch (FS-5U, FS-6)

\* 0 dBu = 0.775 Vrms

\* In the interest of product improvement, the specifications and/or appearance of this unit are subject to change without prior notice.



\* 5 1 0 0 0 2 7 9 6 9 - 0 2 \*