

SmpITrek

User's Manual
Rev.3

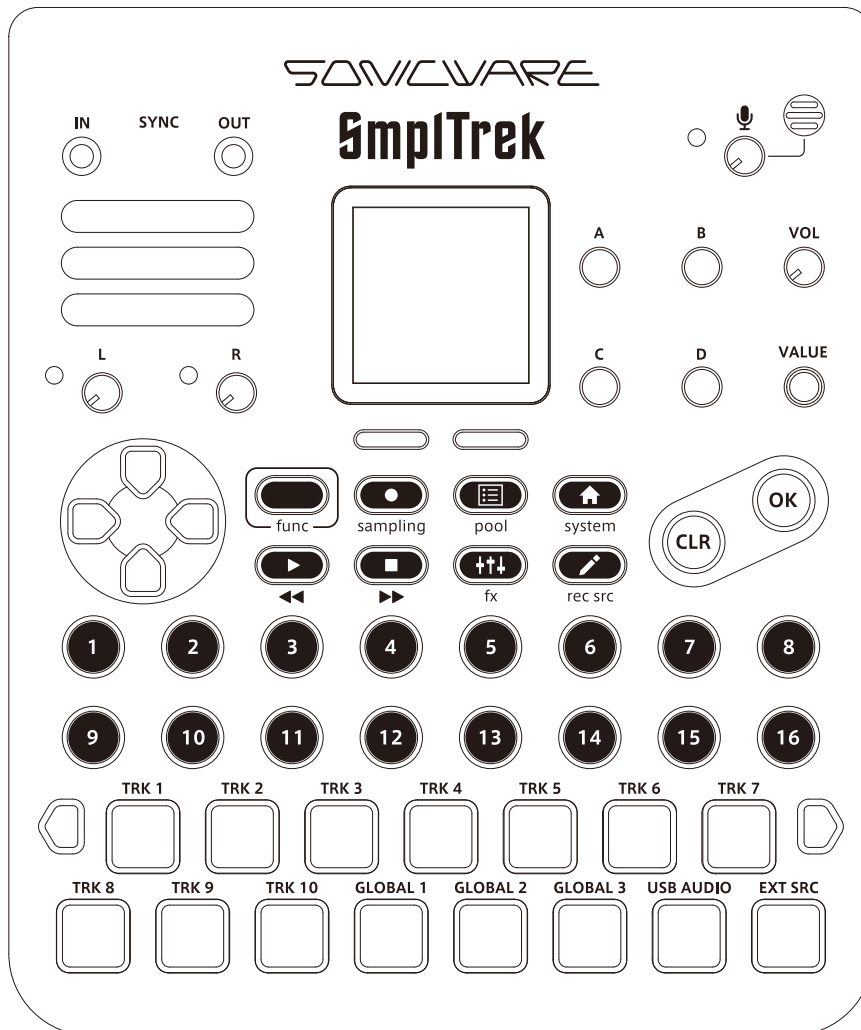

Introduction

Thank you very much for purchasing a SONICWARE SmpITrek.

The SmpITrek is a battery-powered hand-held sampler that can easily capture sounds whenever and wherever using the built-in mic, audio inputs and USB audio sources, for example.

A single song (project) can have up to 16 scenes, and each scene has a 10-track sequencer. In addition, 3 Global audio tracks support long recordings of vocals and instrumental performances.

A choice of 36 effects, including mastering effects, can be used for music production with various track types (loop, one-shot, instrument, drum and MIDI).

Key SmpITrek features

Sample easily whenever and wherever with various inputs and the built-in mic

Sampling can be done with the built-in mic, the line inputs and smartphones, PCs and Macs connected by USB. The built-in effects can also be applied while sampling.

Looper style music production functions

Sampled sounds can be played back using various types of tracks prepared in scenes to produce music.

Various track types

LOOP tracks

These are designed for sampling phrases played on drums, guitars and other instruments and looping them in single scenes.

SHOT tracks

Use these to play one-shot samples, such as sound effects and crash cymbals, once. Sequence patterns can also be made using one-shot samples.

Key SmpITrek features

INST tracks

Use these to play phrases in scales on the keyboard with samples of single notes from pianos, guitars and other real instruments.

DRUM tracks

Use these to make drum patterns with bass drums, snares, hi-hats and other drum sounds.

MIDI tracks

These are piano-roll type sequencer tracks for creating phrases to use with external MIDI equipment.

GLOBAL tracks

These are independent audio tracks that can span multiple scenes. Use these for recording vocals and other performances that continue through a song, for example.

Perform live anywhere

Lightweight, compact and battery-powered

Compact and weighing only 550 grams, the SmpITrek is easy to carry around.

With battery power, music production and streaming are possible anytime anywhere.

Live streaming (audio interface)

By connecting a smartphone or PC/Mac and using the audio interface functions, you can quickly livestream music you have made.

Synchronize with all kinds of devices

Multiple devices, including external synthesizers and drum machines, can be connected to the MIDI and SYNC connectors, allowing them to be synchronized and used together.

Contents

Core function overview	7	Folder structure on cards	34
Names of parts	8	Importing loops from PC/Mac computers	35
Connection example	9	Supported WAV formats	35
Creating songs with the SmpITrek	10	Recommended format	35
Basic operations — General	11	Scene settings	36
Preparing a power supply	11	Making scene settings	36
Starting up	11	Copying scenes	37
Preparing preset data and formatting cards	12	Clearing scenes	38
Formatting and generation of drum kit, instrument and preset project files	12	Basic track operation	39
Important tips to know before use	14	Track types	39
Direction, OK and CLR buttons	14	Setting track types	40
Control and VALUE knobs	14	Copying entire tracks	41
Relationship between built-in speaker and mic	15	Clearing entire tracks	42
Turning LED pad LAUNCH mode on/off	15	Setting the length of the current clip (LENGTH/NOTE)	43
Playing projects and playing scenes	16	Copying clips	44
Differences between monitoring and external source (EXT SRC) sounds	16	Clearing clips	45
Relationship between scene and clip lengths	17	LOOP tracks	46
Relationship between amp and master effects	17	Overview	46
Basic operations — Home Screen	18	LOOP Track Editing Screen	47
Changing the LAUNCH mode	20	Loading samples (SELECT SAMPLE)	48
Master level adjustment	21	Recording in real time	52
Basic operations — Projects	22	Start point in sample (START POS)	53
Selecting projects	22	Looper recording (live sampling)	54
Saving projects	23	SHOT tracks	56
Naming and saving projects	24	Overview	56
Sampling	25	Switching between sequence and pad performance modes	57
Selecting the recording source	25	SHOT Track Editing Screen	58
Sampling the source	26	Loading samples (SELECT SAMPLE)	59
Sampling in time with a metronome or backing track	28	Adjusting sample intervals (POSITION)	62
Using the tuner	29	Recording in real time	64
Resampling	30	Step recording	66
Sample pool	31	Recording pad performances (SHOT REC)	67
Opening the sample pool	31	INST tracks	68
Sample pool basic operations	32	Overview	68
Loading samples	33		

Contents

Loading samples (SELECT SAMPLE)	69	Sampling audio from a smartphone, PC or Mac	104
Setting intervals used and loop points for samples	71	HOLD/GATE	105
Setting envelopes	72	Clearing settings	106
Setting the base note	73	EXT SRC	107
INST Track Editing Screen	74	Overview	107
Real-time recording	75	Setting the input source	108
Step recording	76	Selecting audio files	109
Setting the keyboard scale	77	Making audio file settings	110
Importing SMF files	78	HOLD/GATE	111
DRUM tracks	79	Cross-fading the external source (EXT SRC) and the project sound	112
Overview	79	Clearing settings	113
Selecting kits (SELECT KIT)	80	Other track and clip settings	114
DRUM Track Editing Screen	81	LoFi (LOOP, SHOT)	114
Real-time recording	82	Adjusting levels for individual clips (LOOP tracks)	115
Step recording	83	LoFi (INST, GLOBAL)	116
Setting MIDI note numbers for individual pads	84	PITCH (SHOT)	117
Importing SMF files	85	PITCH (INST)	118
MIDI tracks	86	Mixer	119
Overview	86	Basic mixer screen operation (level meters)	119
MIDI Track Editing Screen	87	Basic mixer screen operation (PRM VALUE)	120
Real-time recording	88	Making specific EQ settings	121
Step recording	89	Muting tracks	122
Setting MIDI CC numbers	90	Effects	123
Setting the scale	91	Insert effects	123
Importing SMF files	92	Send effects	125
GLOBAL tracks	93	Side-chain compression (SC COMP)	127
Overview	93	Master effects	128
GLOBAL Screen basic operations ..	94	Automation	130
Recording	95	Basic automation procedure	131
Splitting regions	97	Editing samples	134
Switching take assignments	98	Chopping (automatic slicing)	134
Joining regions	99	Chopping (manual slicing)	136
Adjusting individual region levels	100	Trimming	138
USB AUDIO track	101	Time stretching	140
Overview	101	Normalizing	142
Connecting a smartphone, PC or Mac to the SmpITrek by USB	102	Mono mixing	143
Playing audio from a smartphone, PC or Mac	103		

Contents

Renaming samples	144	Setting MIDI channels for the unit ...	175
Copying samples to projects	145	Making other MIDI settings	176
Copying samples to the sample pool	146	System settings	177
Deleting samples	147	Pad sensitivity setting	177
Project menu	148	Battery setting	178
Copying projects and saving with new names (SAVE AS)	148	Automatic power off function.....	179
Renaming projects	149	Resetting the unit to the factory default state	180
Deleting projects	150	Checking system version information	181
Mixing down	151	Card functions	182
Exporting stem files	152	Card reader mode	182
Setting project parameters	153	Testing card performance	183
Changing LED pad colors (TRACK COLOR)	154	Formatting	184
Copying tracks (COPY)	155	Firmware updates	185
Clearing tracks (CLEAR)	156	Updating the firmware	185
Changing how many times scenes repeat (REPEAT)	157	Specs	186
Copying scenes (COPY)	158		
Clearing scenes (CLEAR).....	159		
Drum kits	160		
Editing	160		
Adjusting individual instruments on LED pads (INST PRM)	161		
Adjusting drum kit levels and LoFi settings (KIT PRM)	163		
Adjusting drum kit LED pad colors (PAD COLOR)	164		
Checking drum kit sounds with reverb (SEND FX FOR CHECK)	165		
Deleting drum kits (DELETE)	167		
Renaming drum kits	168		
Audio interface	169		
Connecting as an audio interface ...	169		
Quantization	170		
Setting quantization	170		
Clock synchronization with external devices	171		
Connecting with other devices	171		
Setting the clock.....	172		
MIDI	174		
Setting track MIDI channels	174		

Core function overview

Mixer

Adjust the level, panning and other parameters of each track.

Sampling

Sample using the built-in mic and inputs.

Project management

Create new projects and manage existing ones, including selection, renaming and deletion.

Effects

Up to 3 of the 36 built-in effects can be used simultaneously.

PAD

Uses of these velocity-sensitive pads with full-color LEDs include track playback and keyboard performance.

Sample pool

Manage all samples and trim, normalize, stretch and otherwise edit them in the sample pool.

Scenes

A single project is made of up to 16 scenes.

Various tracks

Each scene can have 10 sequencer tracks and 3 global audio tracks.

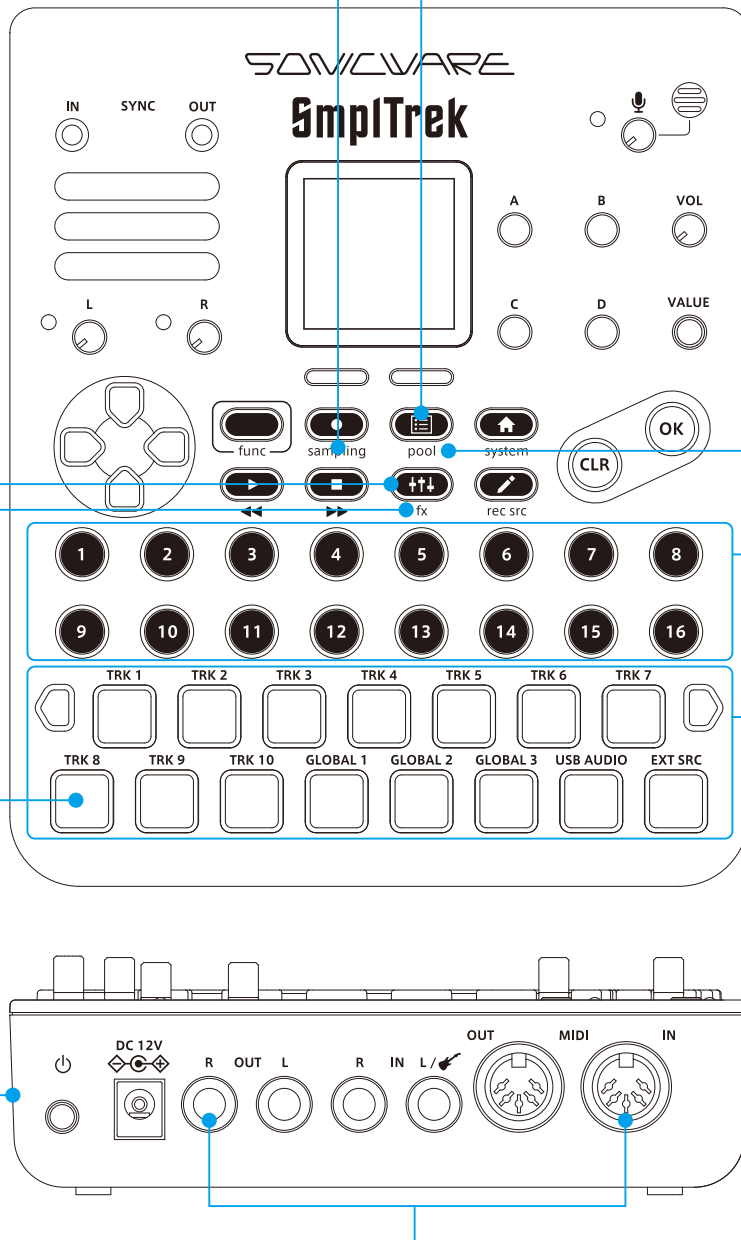

Audio interface

The SmpITrek can be used as a 2-in/2-out audio interface by connecting it by USB to a smartphone or PC/Mac.

Numerous connectors

Along with SYNC IN/OUT jacks, MIDI IN/OUT connectors can be used with external MIDI devices. Other connectors include INPUT jacks with switchable impedance and a built-in mic that is convenient for sampling with just this unit.

Names of parts

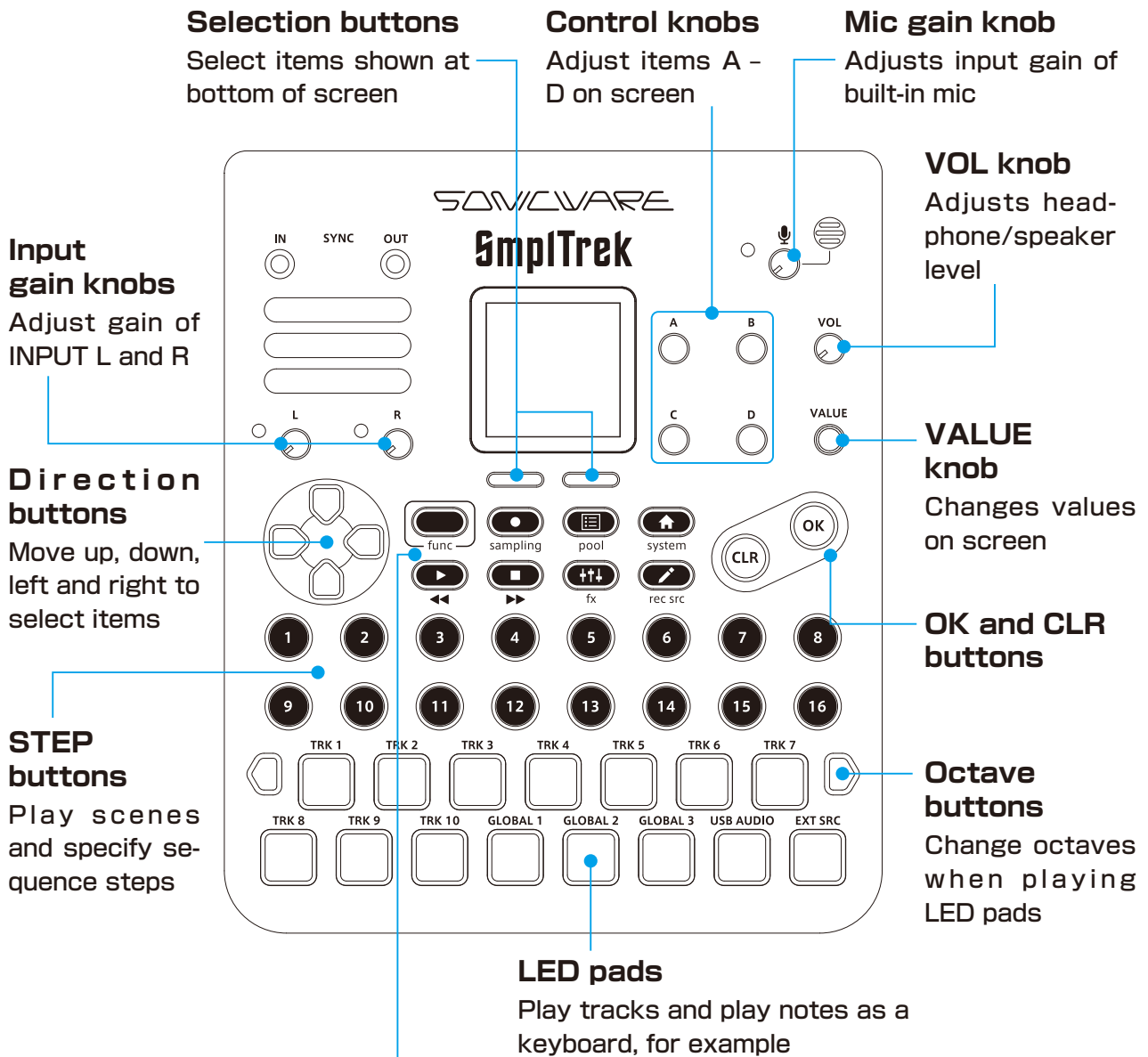

Func button
Press the func button with other buttons to switch to submenus



Rec button
Use for sample and sequence recording

sampling button
Open the SAMPLING Screen



Project button
Open the Project Screen

pool button
Open the POOL Screen



Home button
Open the Home Screen

system button
Open the SYSTEM MENU



Play button
Play projects



Stop button
Stop playback



Mixer button
Open the MIXER Screen



Edit button
Open track editing screens

Rewind button
Move playback position backward

Fast forward button
Move playback position forward

fx button
Open the EFFECTS Screen

rec src button
Open the INPUT SETTING Screen

Connection example

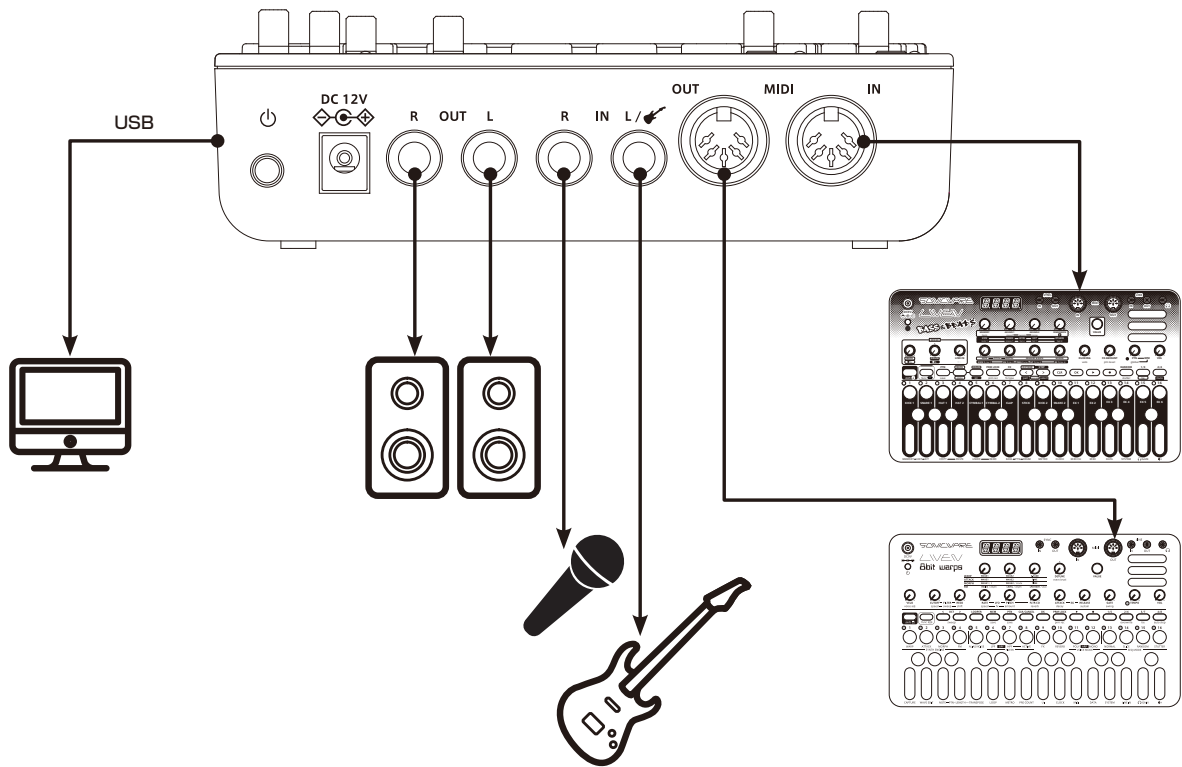

Creating songs with the SmpITrek

One project corresponds to one song.

Track

Each project can have up to 10 tracks. Each track corresponds to a part in the song, for example guitar, bass or drums.

The five types of tracks are LOOP, INST, SHOT, DRUM and MIDI.

The three GLOBAL tracks can be used to record over multiple scenes. Use these for lead and backing vocals, for example.

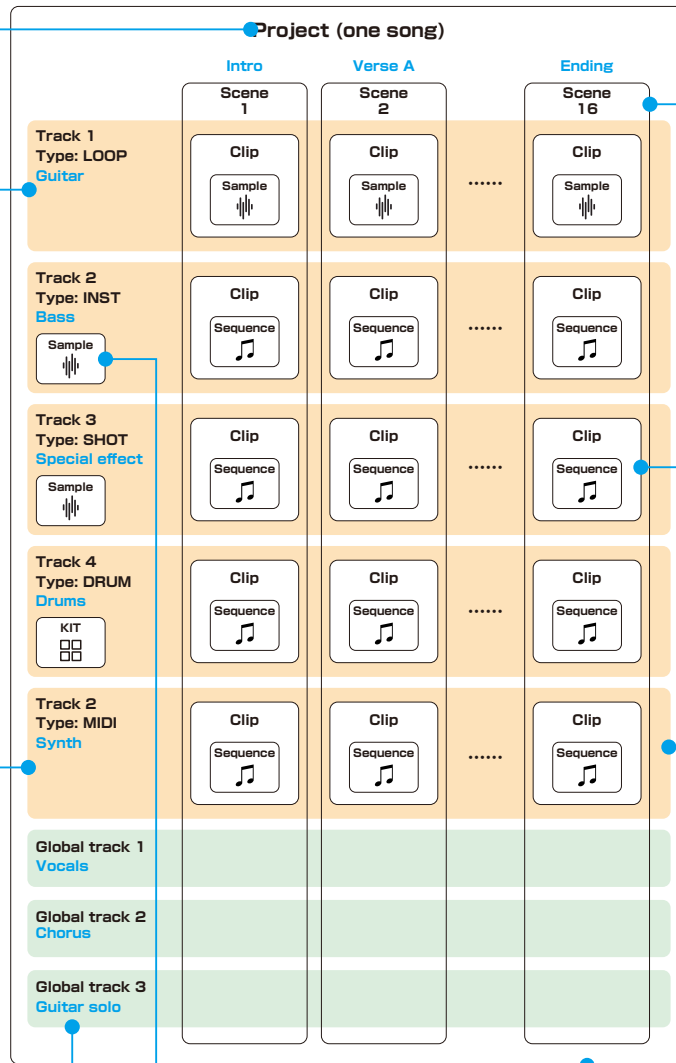

Scene

Each project has 16 scenes.

Each scene makes a somewhat unified section, such as an intro, verse A, verse B, chorus and ending.

Clip

A phrase on a specific track in a specific scene is called a clip.

Even when the scene changes, the track type does not change. For example, if Track 1 is an INST track, it will always function as an INST track in every scene.

The SmpITrek has settings and functions that work on entire scenes, settings and functions that work on entire tracks, and settings and functions that work only on specific clips.

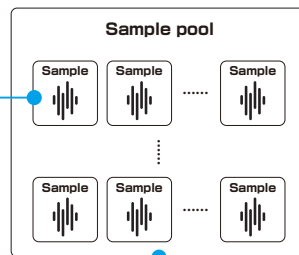

Load samples from the sample pool to use them in LOOP, INST and SHOT tracks.

Basic operations — General

Preparing a power supply

An AC adapter is included.

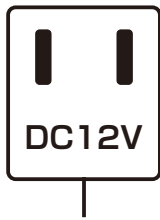

or

6 AA batteries

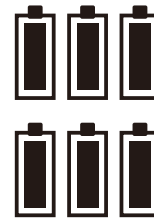

Use only the included AC adapter. Using an AC adapter with different specifications could cause damage.

“Low Battery”  will appear on the display if the remaining battery charge is low. Replace the batteries immediately.



When using nickel-metal hydride batteries or lithium batteries, change the battery setting. (→ P.178)

Starting up

- 1 Press and hold the POWER switch until SmpITrek appears on the display.



Turning the unit off

- 1 Press and hold the POWER switch until the display turns off.

Preparing preset data and formatting cards

Preset data, including drum kits, instrument sound sources and demo projects, are stored inside the SmpITrek. First of all, prepare a blank card and execute **FORMAT & DUPLICATE** on it.

Compatible cards

SDHC up to 32 GB (CLASS 10 or higher)
※ SDXC cards are not compatible.

Formatting and generation of drum kit, instrument and preset project files

- 1 Press **func** + **system** to open the SYSTEM MENU Screen.
- 2 Select **CARD**, and press **OK**.



- 3 Select **FORMAT & DUPLICATE**, and press **OK**.

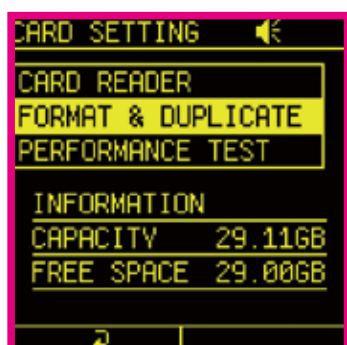

Preparing preset data and formatting cards

- 4 Select **YES**, and press **OK**.



POINT!

- Duplicating files takes a few minutes.
- Be careful because this will erase all data on the card.

Important tips to know before use

Direction, OK and CLR buttons

To keep this manual from becoming too complex, not every item that can be operated using the direction, OK and CLR buttons is explained.

On many screens, the direction, OK and CLR buttons can be used in addition to knobs.

Control and VALUE knobs

Use these to change/adjust parameters shown on the screen.

These knobs are also switches. They are mainly used in the following two ways.

Precise parameter adjustment

Turning knobs for parameters that have many steps will change the value by 10 or 100 steps at a time, for example. (PITCH is one such parameter.)

Precise adjustments can be made by **pressing a knob while turning it**.



Menu opening



⏴ When a downward pointing arrow is shown for a parameter, **pressing the knob** will open that menu.





Important tips to know before use

Relationship between built-in speaker and mic

When the built-in mic is selected as the input source, the built-in speaker will automatically be turned off. (→ P.25)

	Built-in speaker on Built-in mic off
	Built-in speaker off Built-in mic on

Turning LED pad LAUNCH mode on/off

By default, pressing an LED pad  will **select** that track and **start playing** it simultaneously. To select a track without playing it, press the left  **LAUNCH** button to turn LAUNCH mode off.





LAUNCH mode on/off

Important tips to know before use

Playing projects and playing scenes

The SmpITrek has two types of playback: project and scene. Their features are as follows.

	Project playback	Scene playback
Starting playback	Press  .	Press  -  for the desired scene.
Repetition	Playback will not repeat. Scenes will switch automatically in ascending order.	The playing scene will play repeatedly.
Global tracks	These will be played back.	These will not be played back.

Differences between monitoring and external source (EXT SRC) sounds

Sound is different as follows when input monitoring is enabled on the REC SRC Screen, when EXT SRC is set to INPUT, and when recording or auditioning loop and global tracks.

	Insert effects	Reverb	Level
When monitoring is on (→ P.25)	Not applied.	Not applied.	Depends on REC SRC Screen setting.
When EXT SRC is on (→ P.107)	Applied.	Depends on EXT SRC setting in mixer.	Depends on EXT SRC setting in mixer.
During LOOP/ GLOBAL auditioning or recording	Applied.	Depends on track setting in mixer.	Depends on track setting in mixer.

Enable EXT SRC to apply effects to inputs.

Important tips to know before use

Relationship between scene and clip lengths

Scene lengths are given priority over clip lengths.

For this reason, clips will be adjusted to match the scene length. The playback of clips will be looped if the scene is longer or cut off if the scene is shorter.

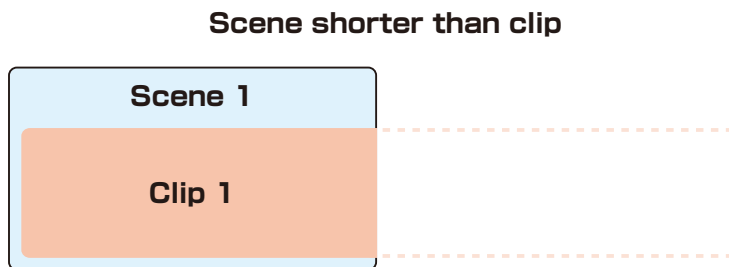
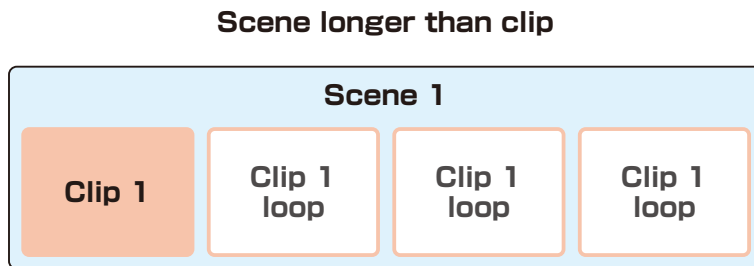

Relationship between amp and master effects

The master effect will be bypassed when an amp type effect is selected and turned on because the processing required for amp insert effects is higher.

To use the master effect, turn off the amp effect or select a different type of insert effect.

Basic operations — Home Screen

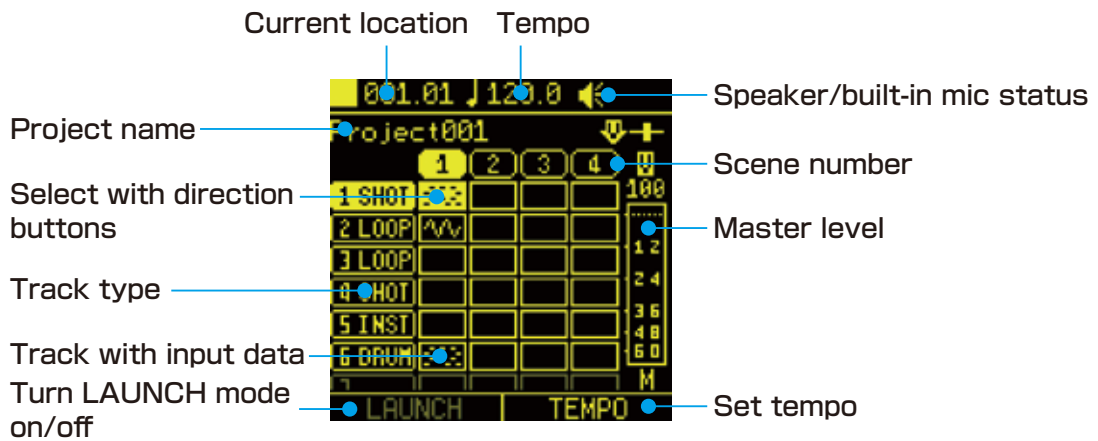

Stop playback

This stops playback of the project/scene. Press again to return to the beginning of the project.

Adjust the master level

Set the tempo

Press the right selection button to open the TEMPO Screen.

Use or (tap) to change the tempo.

Play the project

This plays the project.

Open the Home Screen

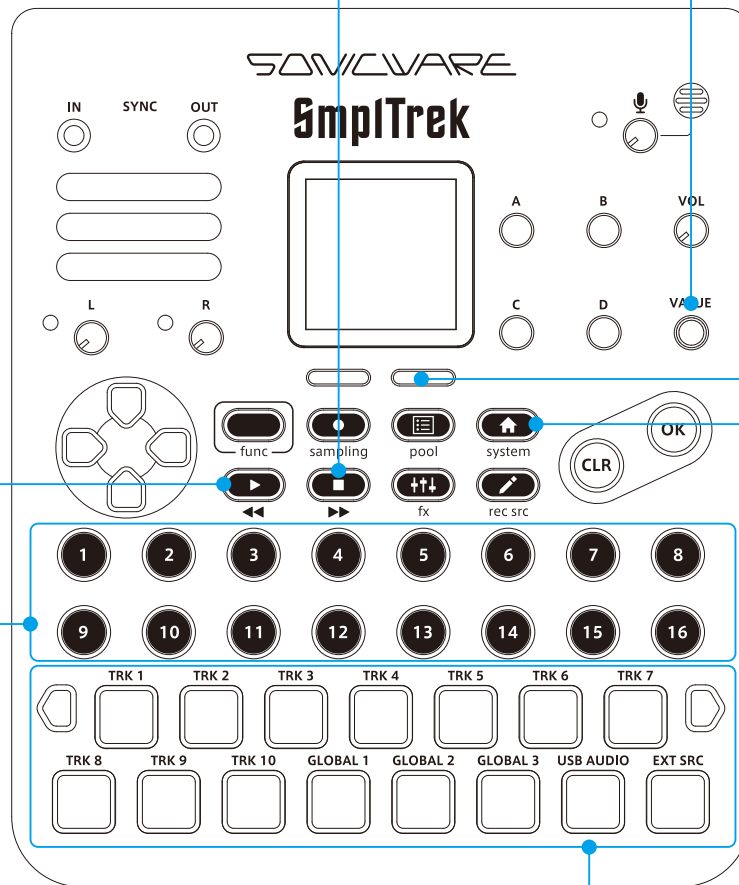

When LAUNCH mode is on

Playing and switching scenes

Press the STEP button for a scene to start playing it in a loop. Press it again to stop.

If another STEP button is pressed during playback, that scene will start playing after the current scene finishes.

When LAUNCH mode is off

Select scenes

When LAUNCH mode is on

Start/stop track playback

Press the LED pad for a track to start playing it. Press it again to stop.

When LAUNCH mode is off

Select track

(The track will not start playing.)

Basic operations — Home Screen

LED pad status	
Selected	<input type="checkbox"/> Lit white
Playing	<input type="checkbox"/> Blinking white
Recording	<input checked="" type="checkbox"/> Lit red
Recording standby	<input checked="" type="checkbox"/> Blinking red
Playback standby/ paused	<input checked="" type="checkbox"/> Blinking green
Playing	<input checked="" type="checkbox"/> Gently blinking green
Data loaded	<input checked="" type="checkbox"/> Lit in set color
Empty	<input type="checkbox"/> Unlit

Scene button status	
Data loaded	<input checked="" type="checkbox"/> Lit yellow
Playing	<input checked="" type="checkbox"/> Lit green
Selected	<input checked="" type="checkbox"/> Lit orange
Unavailable/empty	<input type="checkbox"/> Unlit

Basic operations — Home Screen

Changing the LAUNCH mode

The **LAUNCH mode** used by the SmpITrek can be turned on/off. When on, pressing LED pads and scene buttons will start playback of tracks and scenes immediately.

Turn it on for live performance, and turn it on/off as necessary during production.

- 1 Press the left **LAUNCH** button. This turns it on/off.

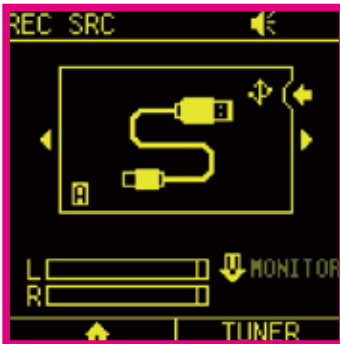

ON



OFF

Launch Mode		
ON	<input checked="" type="radio"/> ① - ⑯	Play and cue scenes
	<input type="checkbox"/> LED pads	Play tracks
OFF	<input checked="" type="radio"/> ① - ⑯	Select scenes
	<input type="checkbox"/> LED pads	Select tracks

Basic operations — Home Screen

Master level adjustment

- 1 Turn  VALUE on the Home Screen. This adjusts the master level.

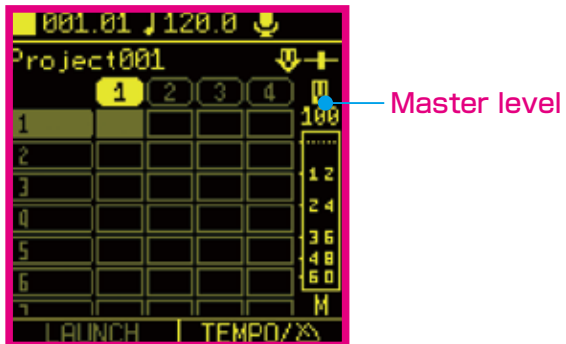

Basic operations — Projects

Selecting projects

1 Press .

2 In the PROJECT MENU, select **SELECT/NEW**.



3 Turn  VALUE to select a project, and press  or  VALUE.

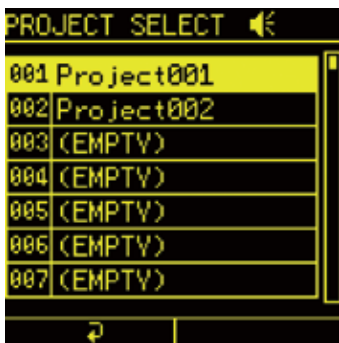

Basic operations — Projects

Saving projects

- 1 Press .
- 2 In the PROJECT MENU, select **SAVE**.



- 3 Select **YES**.

Basic operations — Projects

Naming and saving projects

1 Press .

2 In the PROJECT MENU, select **SAVE AS**.



3 Select **(EMPTY)**, and press .

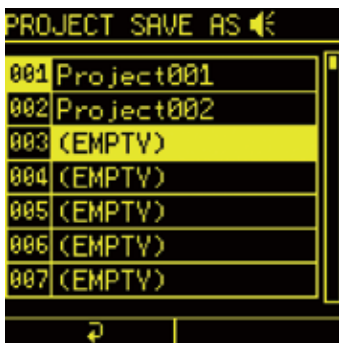





4 Input the name, and press the right  **OK** button.

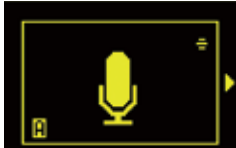

Sampling

Selecting the recording source

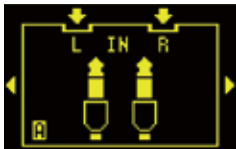
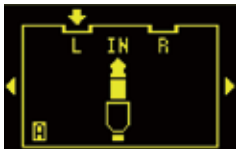
- 1 Press **func** + **rec src**. (The button lights orange.)
- 2 Turn **⏸A** to select the input source.

Rec Src			
⏸A	Explanation	⏸c	Connectors used
	Built-in mic		
	Hi-Z with guitar, bass, etc.	Gain control	INPUT L
	Dynamic mic	Gain control	INPUT R
	Stereo line input	PAD ON/OFF	INPUT L/R
	Mono line input	PAD ON/OFF	INPUT L
	USB		USB
	Resampling	Track selection	

- 3 Press **⏸VALUE** to turn on monitoring.
When monitoring is on, use **⏸VALUE** to adjust the monitoring level.

Sampling

Sampling the source

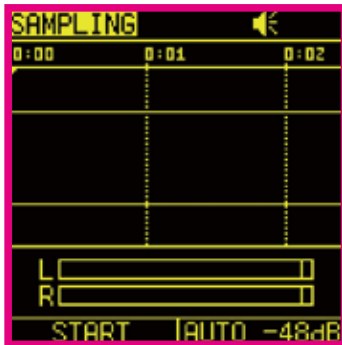

- 1 Press  + .

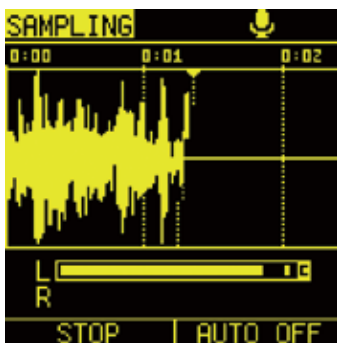

- 2 Press  or the left  button to start sampling.



- 3 Press  or the left  button again to stop.

- 4 Press  to check the sampled sound. If it is OK, press the right  **SAVE** button.

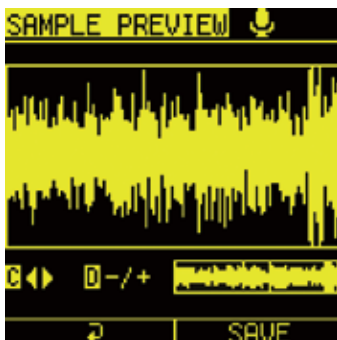

Sampling

- 5 Select the save destination.



Sample Saving	
Option	Explanation
POOL	This saves to the sample pool.
CURRENT PROJECT	This saves to the current project folder. After saving, it can be assigned directly to a track.

- 6 Input the name.



- 7 Press **OK**.

- 8 Select **SKIP**.
See (→ P.134) . to use the **CHOP** function.

Sampling

Sampling in time with a metronome or backing track

1 Press  + .

2 In the SYSTEM MENU, select **METRONOME**.



3 Turn  to adjust the metronome volume.

4 Press  +  to open the SAMPLING screen.

5 Press the  button for a scene to use for backing to start playing it.

6 Press the left  **START** button or  to start sampling.

7 Press the left  **STOP** button or  to stop sampling.

POINT!

- Depending on the quantization setting, sampling will not start until the beginning of the scene.
To change the quantization setting, see (→ P.170) .

Sampling



Using the tuner

- 1 Press  + .

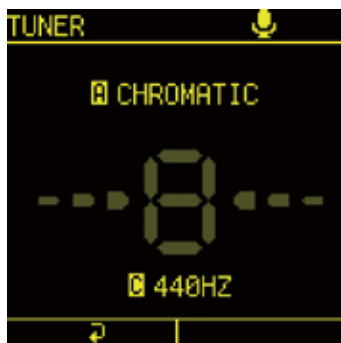

- 2 Press the right  **TUNER** button.



Tuning		
 A	TYPE	Chromatic, Guitar, Bass
 B	CALIB	435 - 445 Hz

Sampling

Resampling

- 1 Open **REC SRC**, and use ⏮ to select resampling.

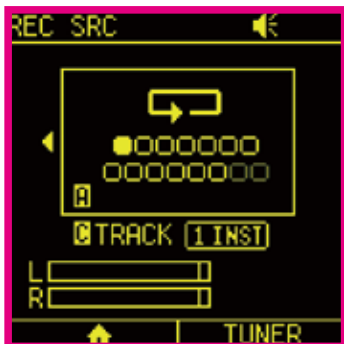

- 2 Use ⏮ to select the track to use.
- 3 Press func + sampling to open the SAMPLING screen.

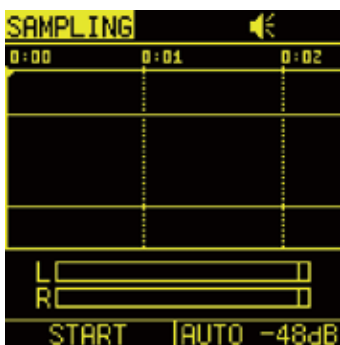

- 4 Use ⏮ to play the scene.
- 5 Press the left ⏮ **START** button or OK to start sampling.
- 6 Press the left ⏮ **STOP** button or OK to stop sampling.

Sample pool

Opening the sample pool

- 1 Press **func** + **pool** to open the POOL Screen, and select **SAMPLE**.



- 2 Use **⌘** or **VALUE** to select a folder that contains samples, and press **OK** or **VALUE**.



Sample Pool	
Option	Explanation
PRESET	Preset sample folder
POOL	Folder where all samples that can be used in projects are saved
PROJECT	Folder that only contains samples used in the current project
FAVORITE	List of samples that have been marked as favorites
PROJECT FAV	List of samples in the current project that have also been marked as favorites

Sample pool

Sample pool basic operations

- 1 Open the SAMPLE POOL Screen and select any sample.

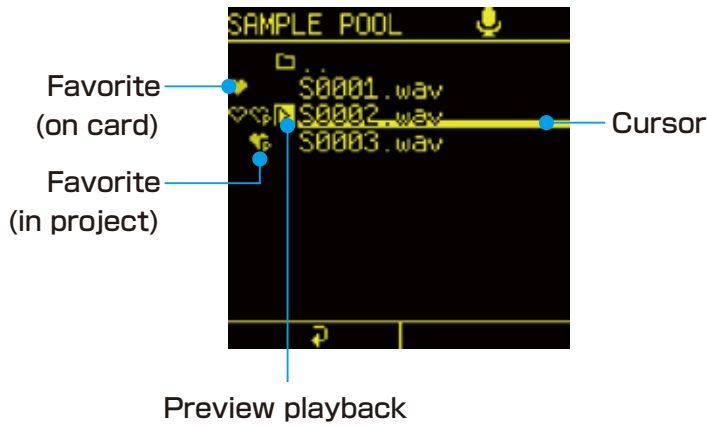

Move cursor up/down or turn VALUE and use for same operation

Move cursor up, down, left and right

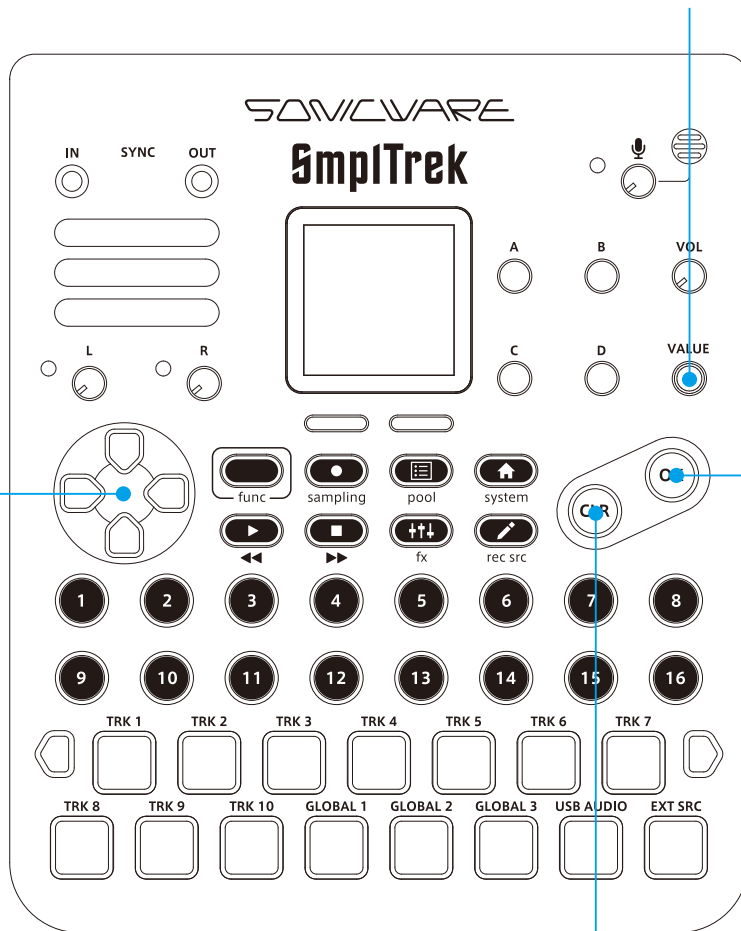

OK button

- Open sample folder
- Work with file or open menu
- Preview or mark FAVORITE

CLR button

Back to parent folder

Sample pool

Loading samples

- 1 Open the SAMPLE POOL Screen and select any sample.

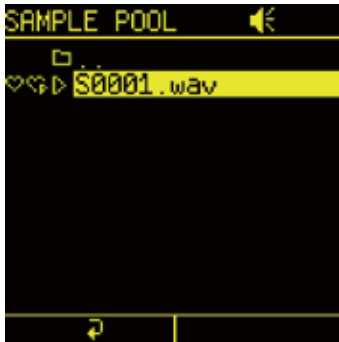

- 2 Press **OK** to open a pop-up menu, and select **LOAD**.

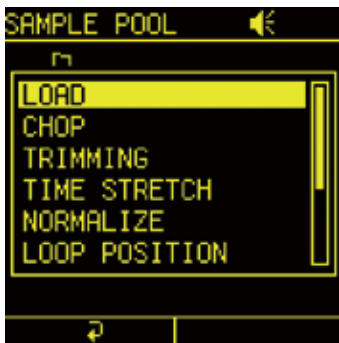

- 3 Select the track for loading the sample and press **OK** or the right **LOAD** button.



- 4 Following instructions on screen, select the track type and the interval used.

Sample pool

Folder structure on cards

The folder structure on cards used in the SmpITrek is as follows.

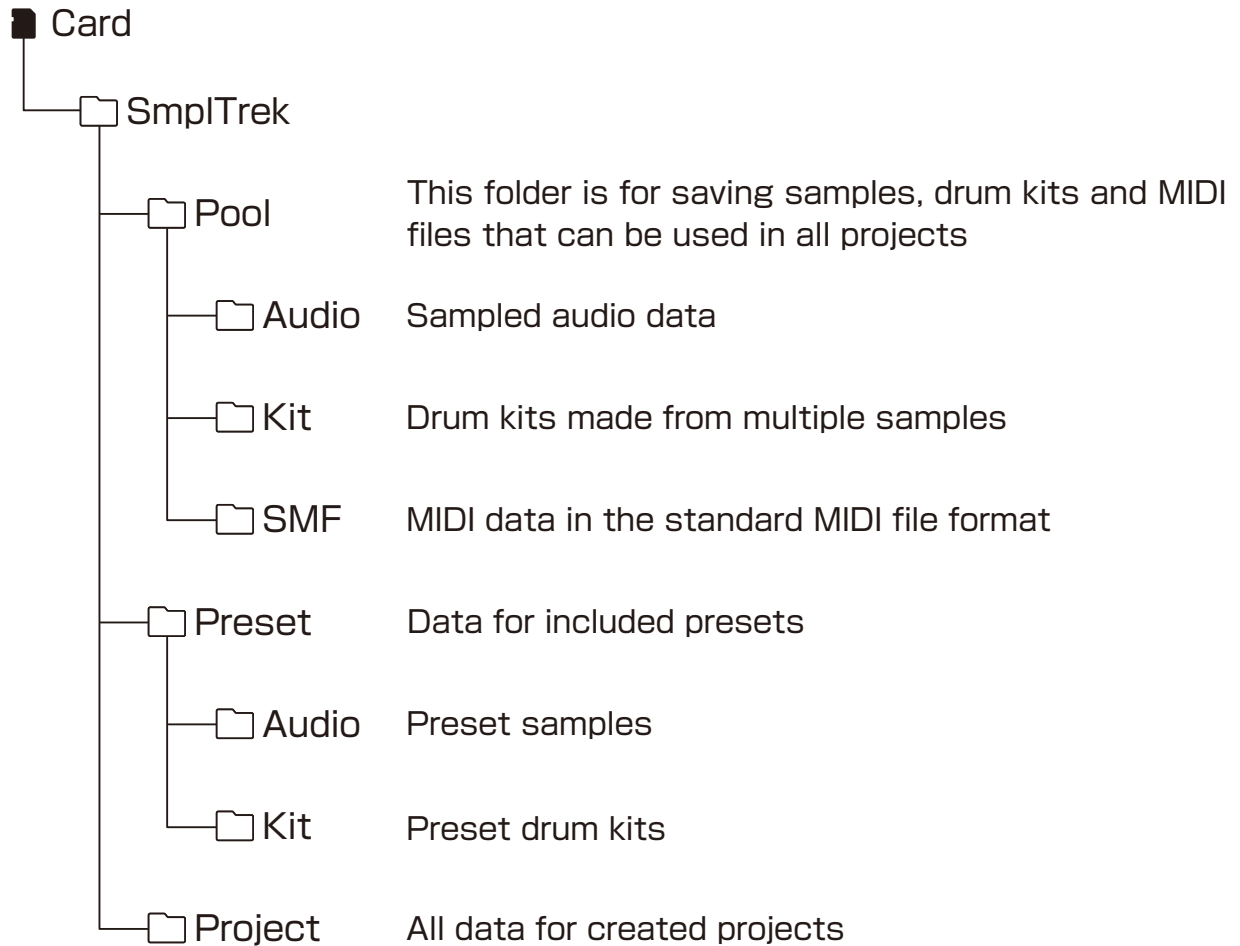

Sample pool

Importing loops from PC/Mac computers

- 1** Connect a card formatted by this unit to the PC/Mac.
- 2** Copy WAV files to the card > SmpITrek > Pool > Audio folder, and insert the card in the unit again.
- 3** Open the Pool Screen and select the file to load. (→ P.33)

Supported WAV formats

Sampling frequency	44.1 - 96 kHz
Bit depth	16 - 24 bit

The SmpITrek uses 48kHz/16-bit WAV files.

Recommended format

48kHz/16-bit WAV

Scene settings

Making scene settings







- 1 Press **func** + **●** for the desired scene to open its Scene Settings Screen.



POINT!

- Playback will stop if another scene or a project is playing.

- 2 Set each item.

SCN SETTING		
Item		Explanation
Page 1		
	BAR	Change the scene length in bars
	TIME SIG	Change the scene time signature
	REPEAT	Set how many times the current scene is repeated during project playback
	ENABLE	Turn the scene on/off When off, it will be skipped during project playback
Page 2		
	COPY TO	Copy the scene
	CLEAR	Clear the scene

Scene settings

Copying scenes

- 1 Press func + O for the scene to be copied to open its Scene Settings Screen.
- 2 Press the right 2/2 button to open the second page.



- 3 Turn A to select the copy destination.
- 4 Press A **COPY TO**, and select **YES**.

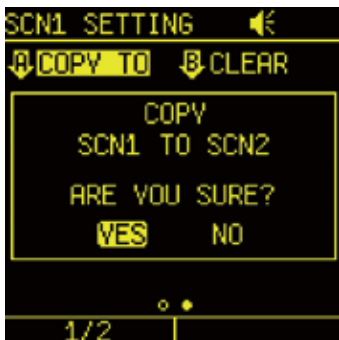

Scene settings

Clearing scenes

- 1 Press  +  for the scene to be cleared.



- 2 Press the right  **2/2** button to open the second page.



- 3 Press  **CLEAR**, and select **YES**.

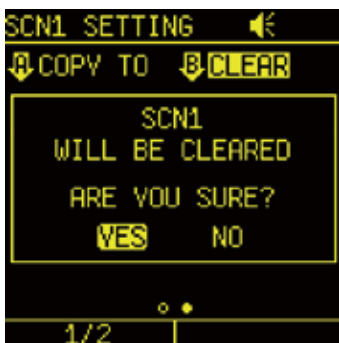

This clears the scene.

Basic track operation

Track types

LOOP tracks

These are designed for sampling performances with drums, guitars and other instruments and looping them in the scene.

SHOT tracks

Use these to play one-shot samples, such as sound effects and crash cymbals, once. Sequence patterns can also be made using one-shot samples.

INST tracks

Use these to play phrases in scales on the keyboard with samples of single notes from pianos, guitars and other real instruments.

DRUM tracks

Use these to make drum patterns with bass drums, snares, hi-hats and other drum sounds.

MIDI tracks

These are piano-roll type sequencer tracks for creating phrases to use with external MIDI equipment.

GLOBAL tracks

These are independent audio tracks that can span multiple scenes. Use these for recording vocals and other performances that continue through a song, for example.

Basic track operation

Setting track types

- 1 Select an empty track, and press  or .

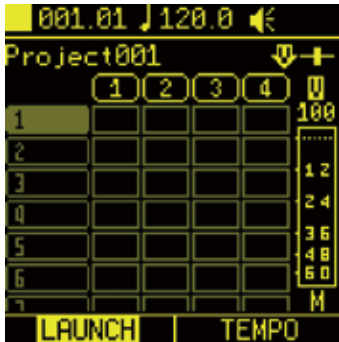

- 2 Select the desired track type from the pop-up menu, and press .



Basic track operation

Copying entire tracks

- 1 Press **func** + **[]** for the track to be copied.



- 2 Press the right **[]** button to open the next page, if **COPY TO** is not displayed.

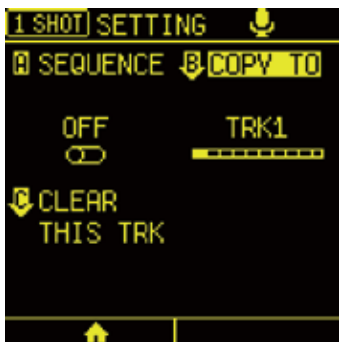

- 3 Turn **[] COPY TO** to set the copy destination.
- 4 Press **[] COPY TO**, and select **YES**.

Basic track operation

Clearing entire tracks

- 1 Press **func** + **□** for the track to be cleared.



- 2 Press the right **○** button to open the next page, if **CLEAR THIS TRK** is not displayed.

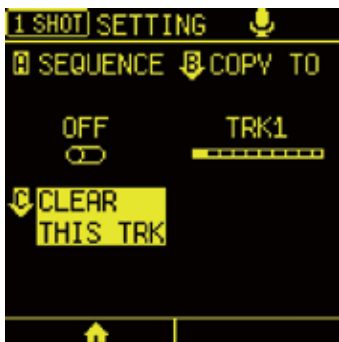

- 3 Press **⏏** **CLEAR THIS TRK**, and select **YES**.

Basic clip operation

Setting the length of the current clip (LENGTH/NOTE)

The length (time) of a clip is determined by **the length of one step** × **the number of steps**.



- 1 Select a clip, and press  or  to open the Editing Screen.

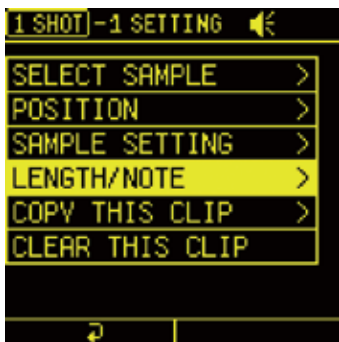

- 2 Press  again to open the SETTING Screen, and select **LENGTH/NOTE**.





- 3 Adjust the **LENGTH** and **NOTE** settings.

Length/note settings		
Item		Explanation
	LENGTH	Number of steps
	NOTE	Length of 1 step

Basic clip operation

Copying clips

- 1 Select the clip to copy, and press  or  to open the Editing Screen.



- 2 Press  again to open the SETTING Screen, and select **COPY THIS CLIP**.

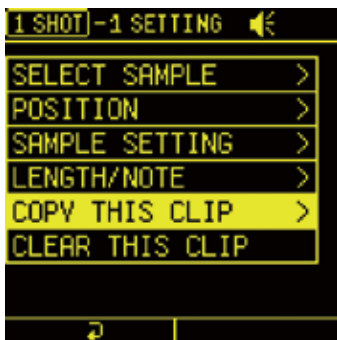



- 3 Turn  to set the copy destination.



- 4 Press  **COPY TO**, and select **YES** to copy.

Basic clip operation

Clearing clips

- 1 Select the clip to clear, and press  or  to open the Editing Screen.



- 2 Press  again to open the SETTING Screen, and select **CLEAR THIS CLIP**.

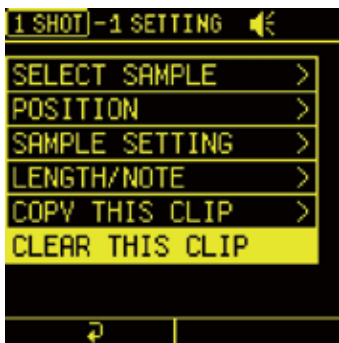

- 3 Select the item to clear from the pop-up menu, and select **YES**.

CLEAR THIS CLIP	
ALL	Clear the clip itself
SEQUENCE	Clear only sequence data
AUTOMATION	Clear only automation data

LOOP tracks







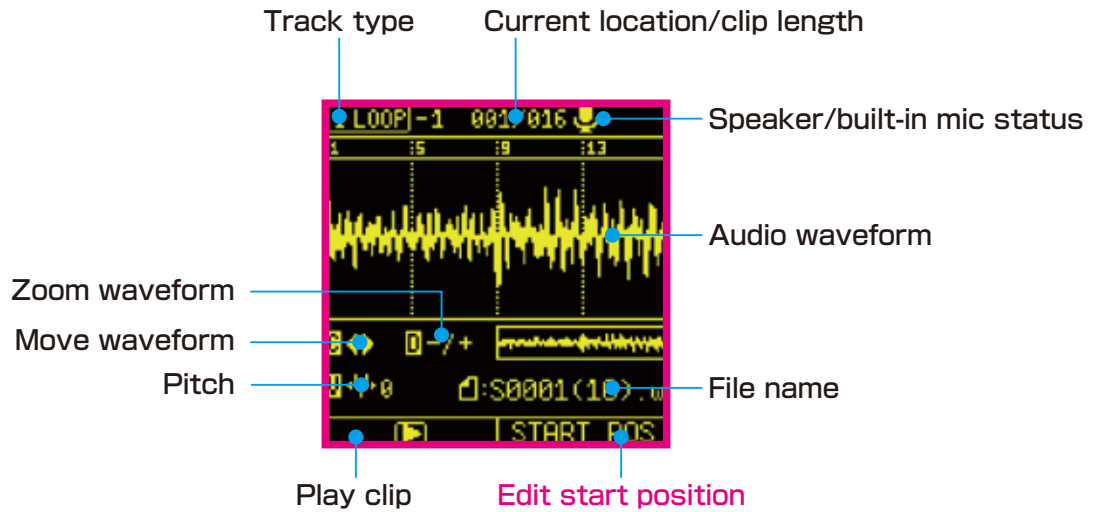

Overview

These are designed for sampling performances with drums, guitars and other instruments and looping them in the scene.

LOOP tracks



LOOP Track Editing Screen





Loop Track Editing	
 c	Move zoomed waveform display
 D	Zoom waveform display
 VALUE	Change pitch
Left 	Play clip
Right 	Open Loop Position Editing Screen
	Open clip menu
	Audition state Sound will pass through the LOOP track channel but will not be recorded
	Recording state
	Play scene

LOOP tracks

Loading samples (SELECT SAMPLE)

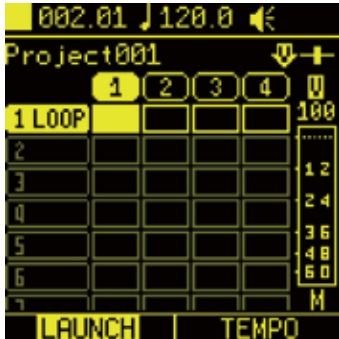
- 1 Select the clip for loading, and press  or  to open the Editing Screen.



- 2 Press  again to open the SETTING Screen, and select **SELECT SAMPLE**.





- 3 Select the desired sample, and press .











POINT!

- Samples can also be loaded from the POOL Screen.
(→ P.31 ~ P.33)

LOOP tracks

- 4** Set the interval used for the sample.
At the BPM BARS position, press  VALUE to select it. Then, turn  VALUE to change the interval setting method (**BPM BARS**, **BPM NOTE STEP** or **AB POINT**).



Sample selection	
 A	Start point in sample
 B	End point in sample (AB POINT)
 C	Move zoomed waveform display
 D	Zoom waveform display
 VALUE	Select/change BPM items
 VALUE	Confirm BPM item selection
Left 	Quit
Right 	Open next menu page

- Determining interval by tempo and bars (**BPM BARS**)



Tempo Number of bars

LOOP tracks

- Determining interval by tempo, note length and number of steps (**BPM NOTE STEP**)

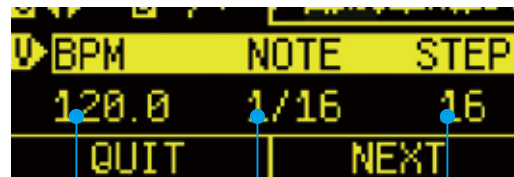

Tempo Note length Number of steps

- Determining interval freely (**AB POINT**)

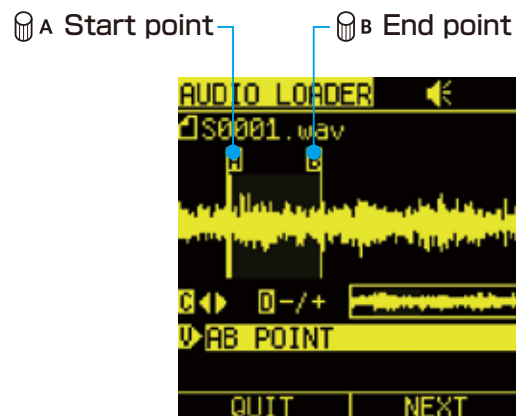

LOOP tracks

- 5** After setting the interval, press the right  **NEXT** button to open the TIME STRETCH Screen.



- 6** To leave it unchanged, select **NO**, and press the right  **NEXT** button.

Time Stretching	
NO	Do not time stretch
YES (MELODIC)	Use time stretching suitable for melodic content
YES (RHYTHMIC)	Use time stretching suitable for rhythmic content



LOOP tracks

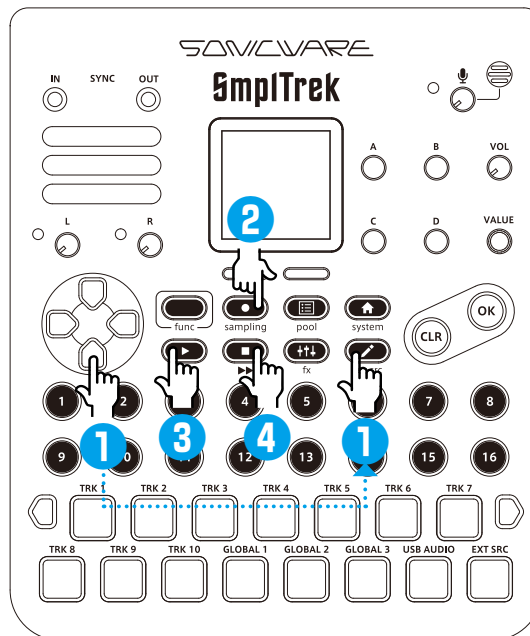

Recording in real time

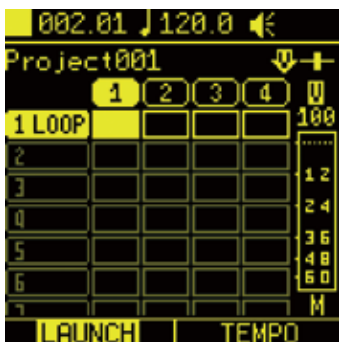

- 1 Select the clip to use for recording, and press .



- 2 Press  twice to start recording standby.
- 3 Press  to start recording.
- 4 When the last step is reached, recording will stop and loop playback will start. Press  to stop playback.

Realtime Recording (Loop Track)	
	Audition state
	Recording state

LOOP tracks

Start point in sample (START POS)



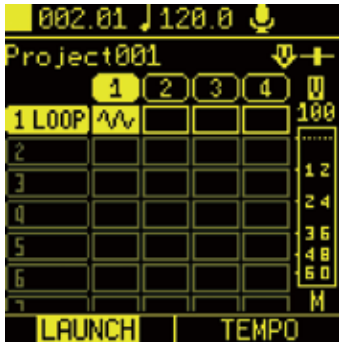

- 1 Select the clip to edit, and press .

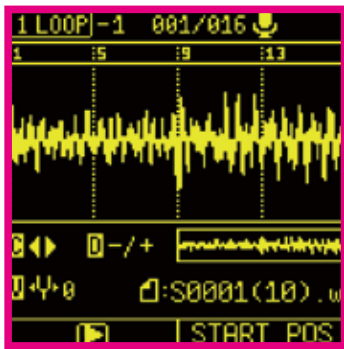

- 2 Press the right  **START POS** button.



- 3 Set each item.

Start Position			
	Loop start point	Left 	Preview playback
	Move waveform display	Right 	Confirm
	Zoom waveform display		

LOOP tracks

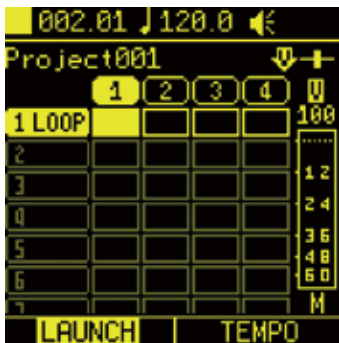

Looper recording (live sampling)

- 1 Set the type to **LOOP** to use a clip for looper recording.



- 2 Press , and select **LOOP REC.**













- 3 Press  -  to start scene playback.
- 4 Press  for the LOOP track to start recording standby. Recording will start automatically according to the SYSTEM MENU **QUANTIZE** (→ P.170) and **LENGTH/NOTE** (→ P.43) settings.

POINT!

- Setting multiple tracks to LOOP type in advance enables performing with looper recording on one track after another.
- Recording lengths depend on the LENGTH/NOTE settings of each LOOP track. (→ P.43)

LOOP tracks

LED pad status	
Selected	 Lit white
Playing	 Gently blinking green
Recording	 Gently blinking red
Data loaded	 Lit in set color
Empty	 Unlit

Scene button status	
Data loaded	 Lit yellow
Playing	 Lit green
Playback paused	 Blinking green
Selected	 Lit orange
Unavailable/empty	 Unlit

SHOT tracks



Overview

Use these to play one-shot samples, such as sound effects and crash cymbals, once. SHOT tracks have a **PAD performance mode** and a **SEQUENCE mode**.

PAD performance mode	Samples are played when LED pads are pressed. This is ideal for live performance.
SEQUENCE mode	Sequences with sample playback timing can be made. This is ideal for playing complicated parts and preparing beats with kicks, for example.

SHOT tracks

Switching between sequence and pad performance modes

- 1 Press  + the SHOT track  to open the SETTING Screen.
- 2 Turn  **SEQUENCE** to turn this mode on/off.

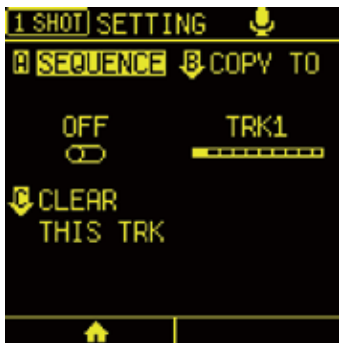

Sequence	
ON	Sequence mode
OFF	Pad performance mode

POINT!

- Pad performance mode will be activated automatically after chopping or assigning samples.
- Sequence mode will be activated automatically after shot recording.

SHOT tracks

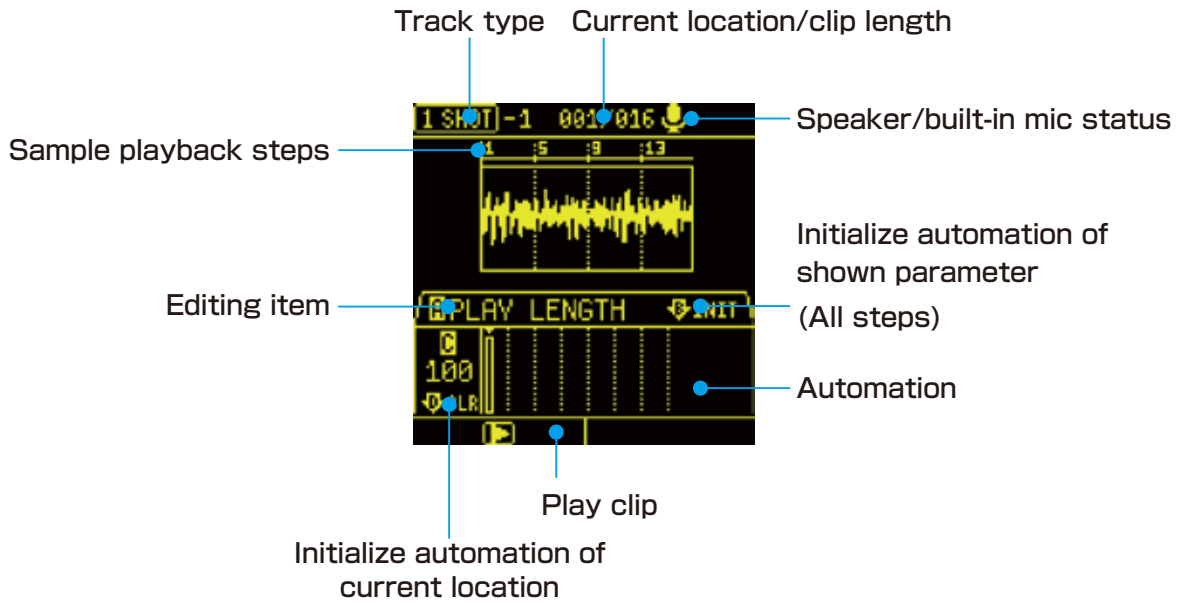

SHOT Track Editing Screen



Shot Track (Edit)			
	Switch editing item		Move by 1 step
	Initialize editing item		Move by 16 steps
	Editing item parameter		Open Settings Screen
	Initialize parameter		Activate recording
	Move between steps		Play scene
	Move between pages while pushing		Input/clear sound triggers during recording
左	Play clip		Input sound triggers during real-time recording
	Move between steps		

SHOT tracks

Loading samples (SELECT SAMPLE)

- 1 Select the clip for loading, and press  or  to open the Editing Screen.



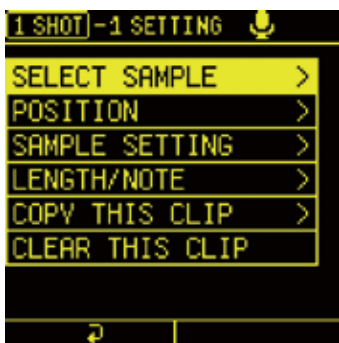

- 2 Press  again to open the SETTING Screen, and select **SELECT SAMPLE**.











- 3 Select the desired sample, and press .



SHOT tracks

- 4** Set the interval used for the sample.
At the BPM BARS position, press  VALUE to select it. Then, turn  VALUE to change the interval setting method (**BPM BARS**, **BPM NOTE STEP** or **AB POINT**).



Sample selection	
 A	Start point in sample
 B	End point in sample (AB POINT)
 C	Move zoomed waveform display
 D	Zoom waveform display
 VALUE	Select/change BPM items
 VALUE	Confirm BPM item selection
Left 	Quit
Right 	Open next menu page

- Determining interval by tempo and bars (**BPM BARS**)



Tempo Number of bars

SHOT tracks

- Determining interval by tempo, note length and number of steps (**BPM NOTE STEP**)

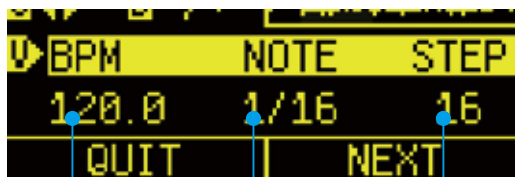

Tempo Note length Number of steps

- Determining interval freely (**AB POINT**)

Ⓜ A Start point Ⓜ B End point



SHOT tracks

Adjusting sample intervals (POSITION)

- 1 Select the clip to edit, and press  or .





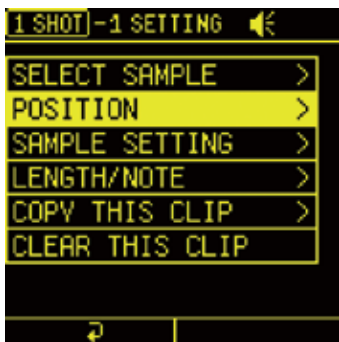



- 2 Press  again to open the SETTING Screen, and select **POSITION**.



- 3 Set each item.



SHOT tracks

Position			
 A	Start point in sample	 VALUE	Move the start point without changing the interval
 B	End point in sample	Left 	Preview playback
 C	Move waveform display	Right 	Confirm
 D	Zoom waveform display		

SHOT tracks

Recording in real time

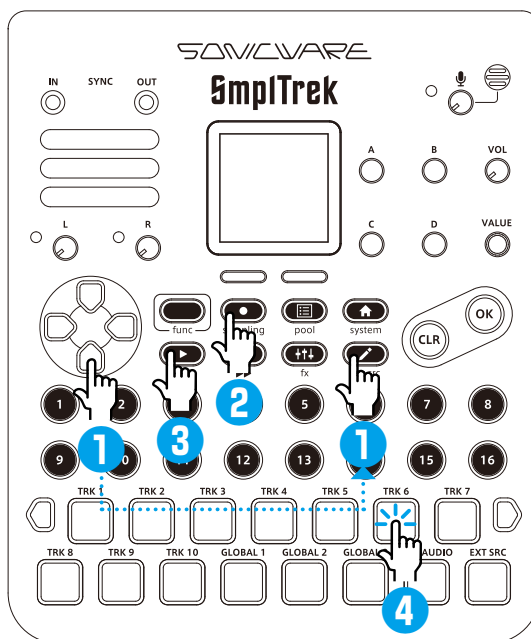

- 1 Select the clip to use for recording, and press or .

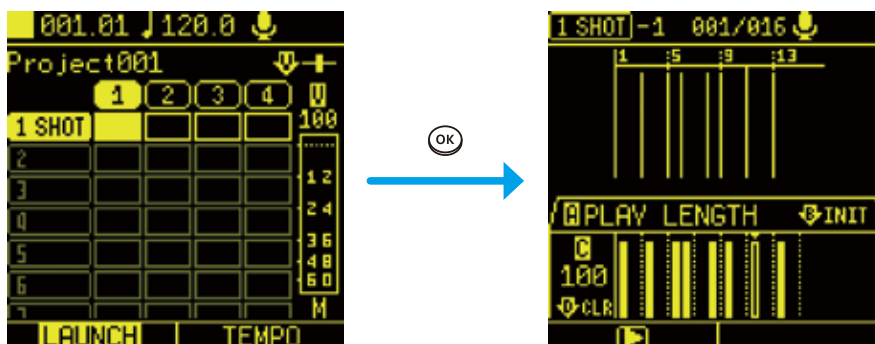

POINT!

- This shows visibly the steps where audio starts.
- Changing pages will move 16 steps at a time. If steps 1-32 are shown, changing pages will show steps 17-48.

- 2 Press to start recording standby.

- 3 Press to start recording.

SHOT tracks

4 Press at the desired input times.

POINT!

- Sound triggers can be input directly on steps by pressing their buttons.

SHOT tracks

Step recording

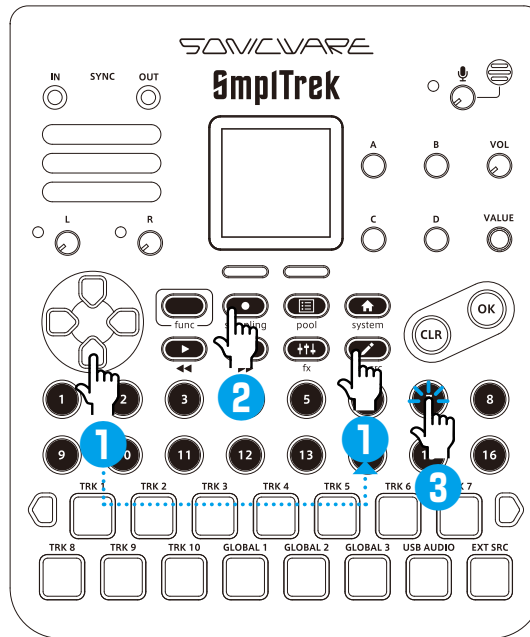

- 1 Select the clip to use for recording, and press or .

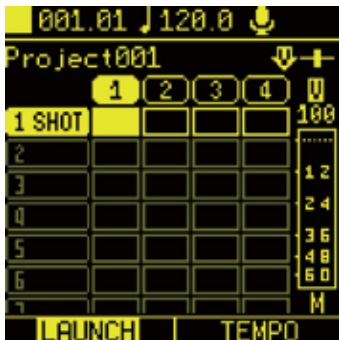

- 2 Press to start recording standby.

- 3 Press for the step to input.



Press for a step that has already been input to clear it.

SHOT tracks

Recording pad performances (SHOT REC)

Using this function, multiple SHOT tracks can be used to perform, creating sequences on each track.

- 1 Prepare SHOT tracks with samples assigned to them beforehand, and select the scene to record.



- 2 Press , and select **SHOT REC**.



This puts the unit into recording standby.

- 3 Press  to start recording, and use the SHOT track pads to perform.

POINT!

- Multiple SHOT track sequences can be input simultaneously. Each clip will loop according to its own length. Set the lengths of clips beforehand. (→ P.43)



INST tracks

Overview

Use these to play phrases in a scale on the keyboard with samples of single notes from pianos, guitars and other real instruments.

INST tracks

Loading samples (SELECT SAMPLE)

- 1 Press  + the INST track  to open the SETTING Screen.
- 2 Press  **SELECT SAMPLE** to open the SAMPLE POOL Screen.



POINT!

- The following table shows the maximum length in seconds of samples that can be loaded on INST tracks.

Mono	10.9 seconds
Stereo	5.46 seconds

- 3 Select the desired sample, and press .

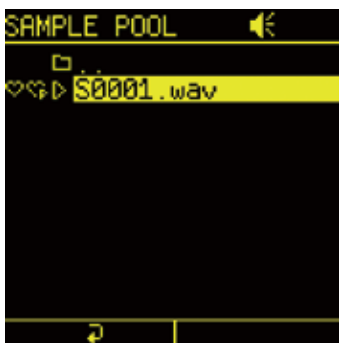

INST tracks

- 4 Following the guidance on screen, adjust the START/END points, and press **OK**.



- 5 The loaded sample can be played using the **□** pads as a keyboard.

INST tracks

Setting intervals used and loop points for samples







1 Press  + the INST track  to open the SETTING Screen.

2 Press  **POSITION SETTING**.



3 Set each item.



Position			
 A	Start point in sample	 VALUE	Switch between START/END and LOOP editing.
 B	End point in sample	Left 	Turn looping on/off
 C	Move waveform display	Right 	Confirm
 D	Zoom wave-form display		

INST tracks



Setting envelopes

1 Press  + the INST track  to open the SETTING Screen.

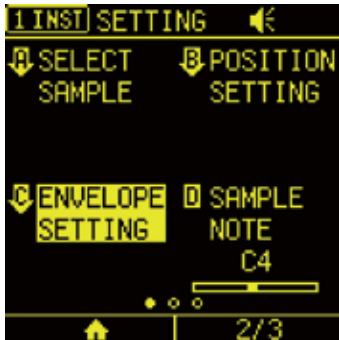
2 Press  **ENVELOPE SETTING**.



3 Set each item.

Position	
 A	Adjust attack
 B	Adjust release

INST tracks

Setting the base note

1 Press  + the INST track  to open the SETTING Screen.

2 Turn  to adjust **SAMPLE NOTE**.



INST tracks

INST Track Editing Screen

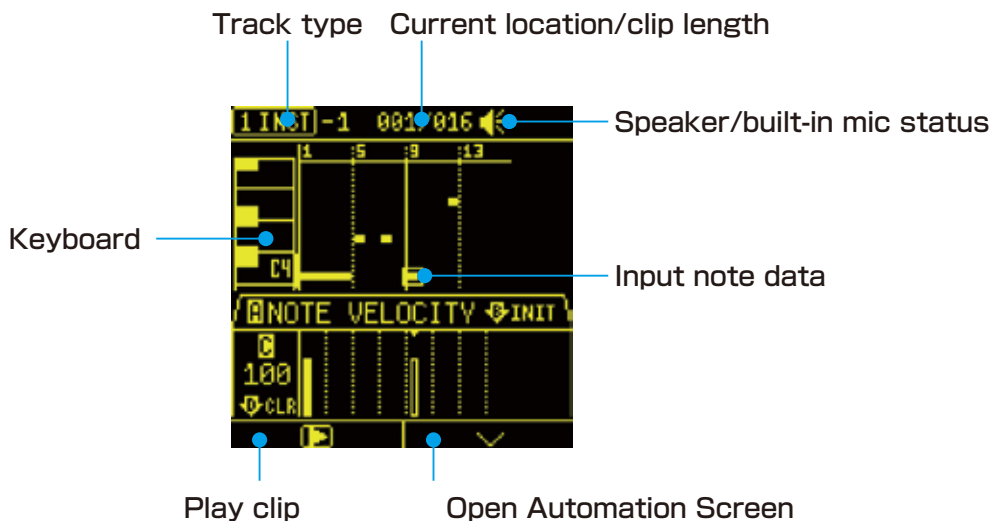

Inst Track (Edit) - Main			
VALUE 	Move between steps	VALUE	Move between pages while pushing
左	Play clip		Move note position
右	Open Automation Screen		Activate recording
	Open Settings Screen		Play scene
	Move note position by octaves with octave buttons / move 1 white key with + octave buttons		

Inst Track (Edit) - Automation			
A	Switch editing item	+	Move note position
B	Initialize editing item	+ 	Move between steps
C	Change item parameter (in steps)		
D	Initialize parameter (in steps)		

INST tracks

Real-time recording

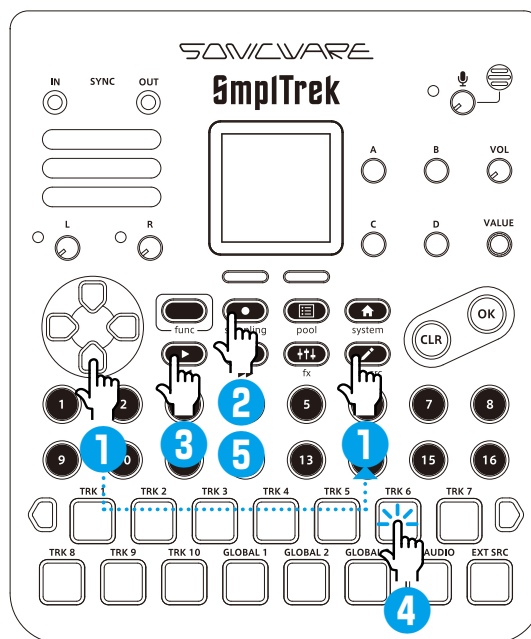

- 1 Select the clip to use for recording, and press or .

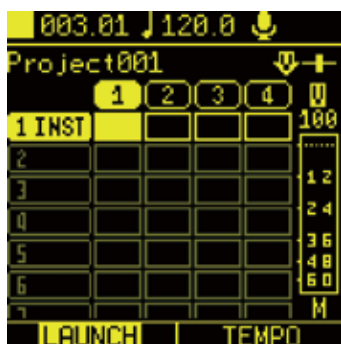

- 2 Press to start recording standby.
- 3 Press to start recording.
- 4 Play to input notes.
- 5 Press to end recording.

INST tracks

Step recording

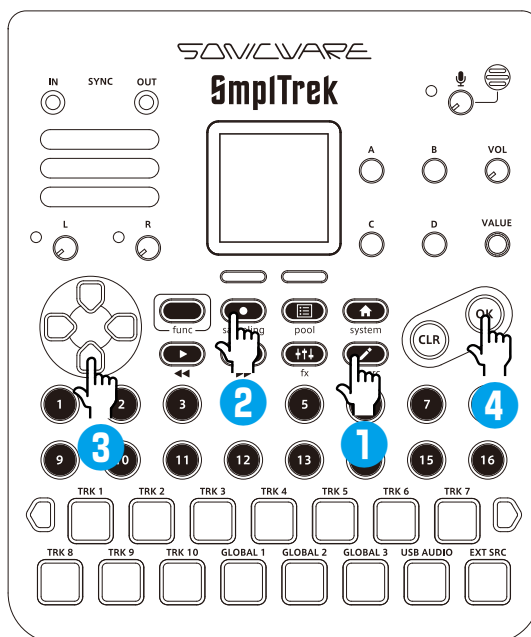

- 1 Select the clip to use for recording, and press or .

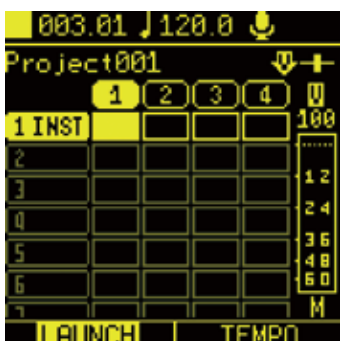

- 2 Press to start recording standby.
- 3 Use , VALUE to move to the step for input.
- 4 Press , or to input a note.
Press these again to clear input notes.

POINT!

- Tied notes can be input by moving between steps while pressing a keyboard pad or .
- Tied notes can be entered by pressing a while pressing another .
- Use , or VALUE to move between steps.

INST tracks

Setting the keyboard scale

- 1 Select a clip, and press  or .

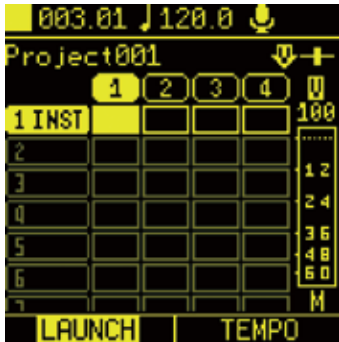



- 2 Press  again to open the SETTING Screen, and select **SCALE SETTING**.

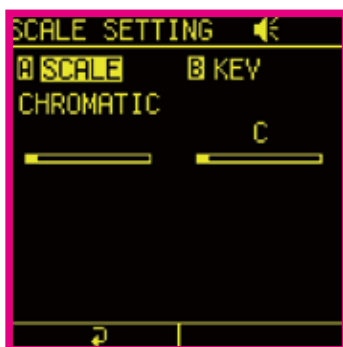

- 3 Set each item.



Scale	
 A	Change the scale
 B	Change the key

LED pads  will become light blue for notes that are outside the scale.

INST tracks

Importing SMF files

- 1 Select the clip to edit, and press  or .

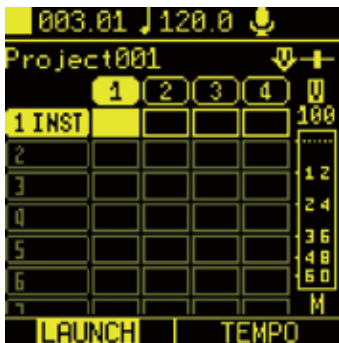

- 2 Press  again to open the SETTING Screen, and select **IMPORT SMF**.



- 3 Select the desired file from the POOL Screen.

POINT!

- SMF format types 0 and 1 are supported. Only note on/off data is imported.
- The Track Selection Screen will open when importing one SMF format file, so select one track as the import destination.

DRUM tracks

Overview

Use these to create drum patterns using drum sounds, including bass, snare and hi-hat, that have been prepared in advance in a drum kit.

Original drum kits can also be made from samples.

DRUM tracks

Selecting kits (SELECT KIT)

- 1 Press  + the DRUM track  to open the SETTING Screen.

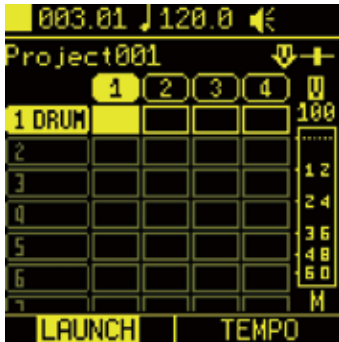

- 2 Press  A **SELECT KIT**.



- 3 Select the desired kit, and press .



- 4 The loaded kit can be played with  when the Drum Track Editing Screen is open.

DRUM tracks

DRUM Track Editing Screen

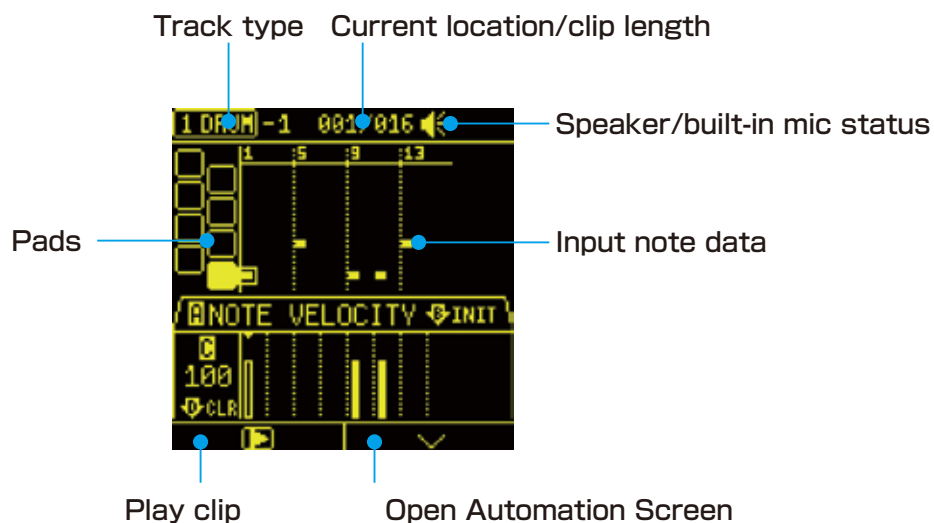

Drum Track (Edit) - Main			
VALUE 	Move between steps	VALUE	Move between pages while pushing
左	Play clip		Move note position
右	Open Automation Screen		Activate recording
	Open Settings Screen		Play scene

Drum Track (Edit) - Automation			
A	Switch editing item	func +	Move note position
B	Initialize editing item	func + 	Move between steps
C	Adjust editing item parameter (in steps)		
D	Initialize parameter (in steps)		

DRUM tracks

Real-time recording

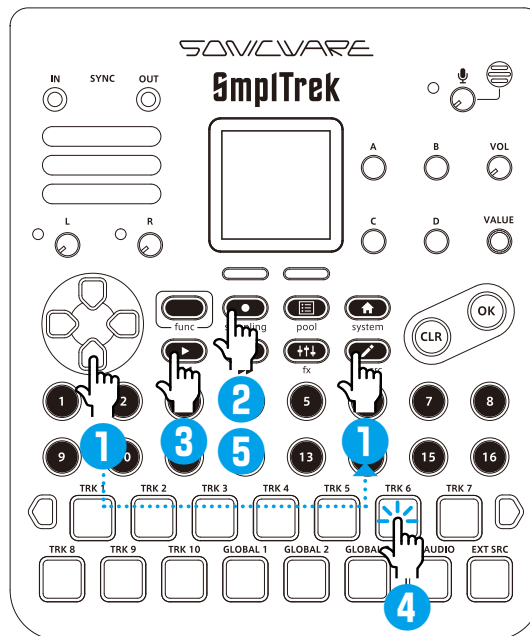

- 1 Select the clip to use for recording, and press or .

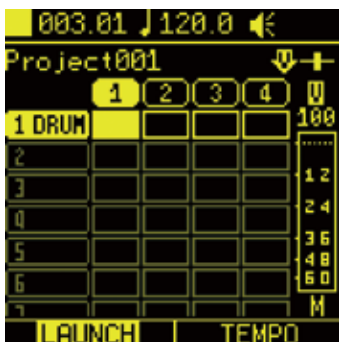

- 2 Press to start recording standby.
- 3 Press to start recording.
- 4 Play to input notes.
- 5 Press to end recording.

DRUM tracks

Step recording

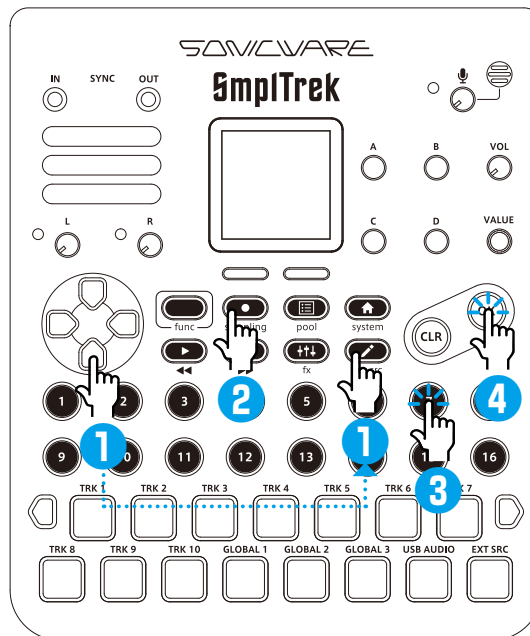

- 1 Select the clip to use for recording, and press or .

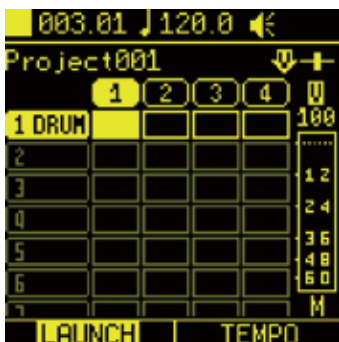

- 2 Press to start recording standby.
- 3 Use , VALUE to move to the step for input.
- 4 Press , or the desired to input a note.

POINT!

- Use , or VALUE to move between steps.

DRUM tracks

Setting MIDI note numbers for individual pads

1 Press  + the DRUM track  to open the SETTING Screen.

2 Press  PAD NOTE NUMBER.



3 Use  and  to select a pad to change.





4 Turn  to change the note number.

DRUM tracks

Importing SMF files

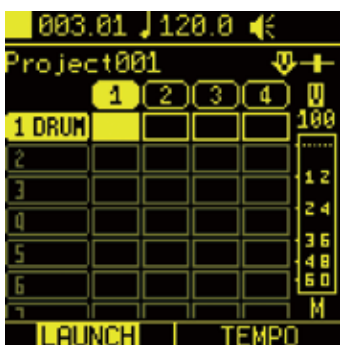
- 1 Select the clip to edit, and press  or .



- 2 Press  again to open the SETTING Screen, and select **IMPORT SMF**.



- 3 Select the desired file from the POOL Screen.

POINT!

- SMF format types 0 and 1 are supported. Only note on/off data is imported.
- Only notes that correspond to note numbers set for the pads will be imported.

MIDI tracks

Overview

These are piano-roll type sequencer tracks for creating phrases to use with external MIDI equipment.

In addition to note on/off, automation can be used to send four types of control change data.

MIDI tracks

MIDI Track Editing Screen

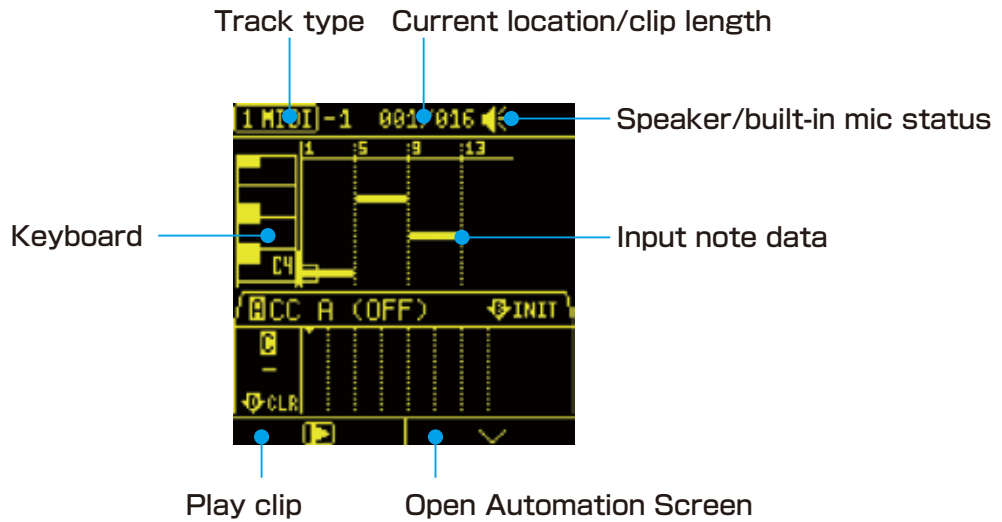

Midi Track (Edit) - Main			
VALUE 	Move between steps	VALUE	Move between pages while pushing
左	Play clip		Move note position
右	Open Automation Screen		Activate recording
	Open Settings Screen		Play scene
	Move note position by octaves with octave buttons / move 1 white key with + octave buttons		

Midi Track (Edit) - Automation			
A	Switch editing item	+	Move note position
B	Initialize editing item	+	Move between steps
C	Adjust editing item parameter (in steps)		
D	Initialize parameter (in steps)		

MIDI tracks

Real-time recording

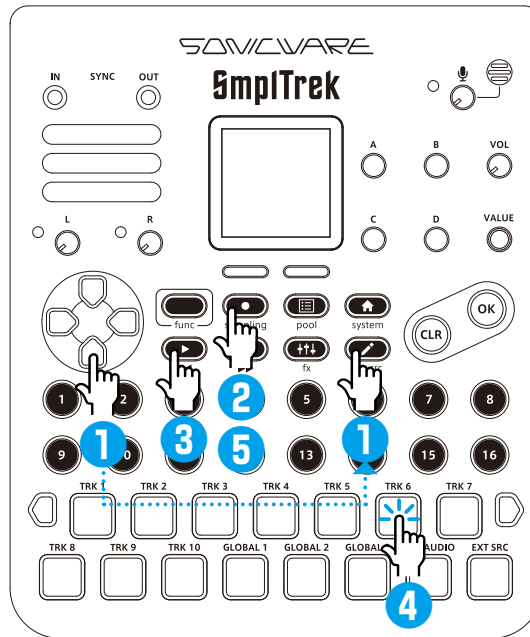

- 1 Select the clip to use for recording, and press or .

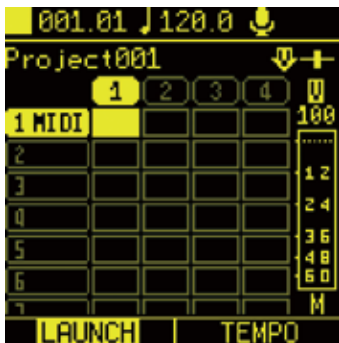

- 2 Press to start recording standby.
- 3 Press to start recording.
- 4 Play to input notes.
- 5 Press to end recording.

MIDI tracks

Step recording

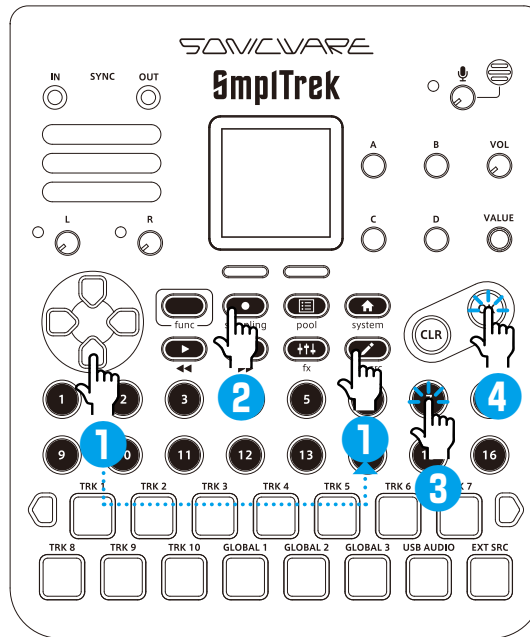

- 1 Select the clip to use for recording, and press or .

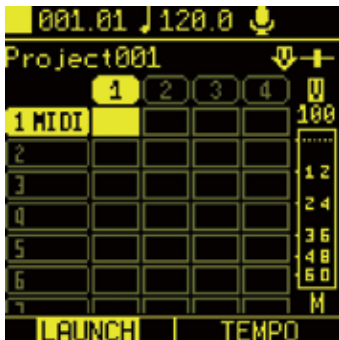

- 2 Press to start recording standby.
- 3 Use , VALUE to move to the step for input.
- 4 Press , or the desired to input a note. Press these again to clear input notes.

POINT!

- Tied notes can be input by moving between steps while pressing a keyboard pad or .
- Use , or VALUE to move between steps.

MIDI tracks

Setting MIDI CC numbers

In addition to notes, MIDI tracks can also transmit up to four types of control change data per step using automation.

In this case, the control change numbers specified by MIDI CC A-D are used.

1 Press  + the MIDI track  to open the SETTING Screen.

2 Turn  -  to change **MIDI CC A-D**.



MIDI tracks

Setting the scale

- 1 Select the clip to edit, and press  or .

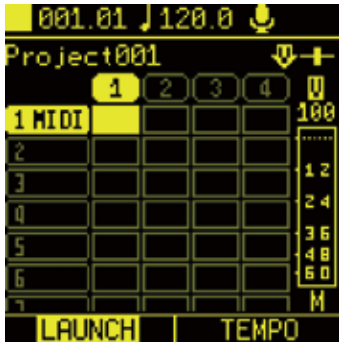



- 2 Press  again to open the SETTING Screen, and select **SCALE SETTING**.



- 3 Set each item.



Position	
 A	Change the scale
 B	Change the key

LED pads will become light blue for notes that are outside the scale.

MIDI tracks

Importing SMF files

- 1 Select the clip to edit, and press  or .

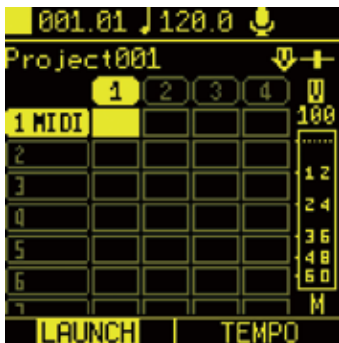

- 2 Press  again to open the SETTING Screen, and select **IMPORT SMF**.



- 3 Select the desired file from the POOL Screen.

POINT!

- SMF format types 0 and 1 are supported. Only note on/off data is imported.

GLOBAL tracks

Overview

These are independent audio tracks that can span multiple scenes. Use these for recording vocals and other performances that continue through a song, for example.

The SmpITrek has 3 GLOBAL tracks, and each of these has 3 virtual (V) takes. In the middle of a song, the 3 V takes can be switched and their levels adjusted.

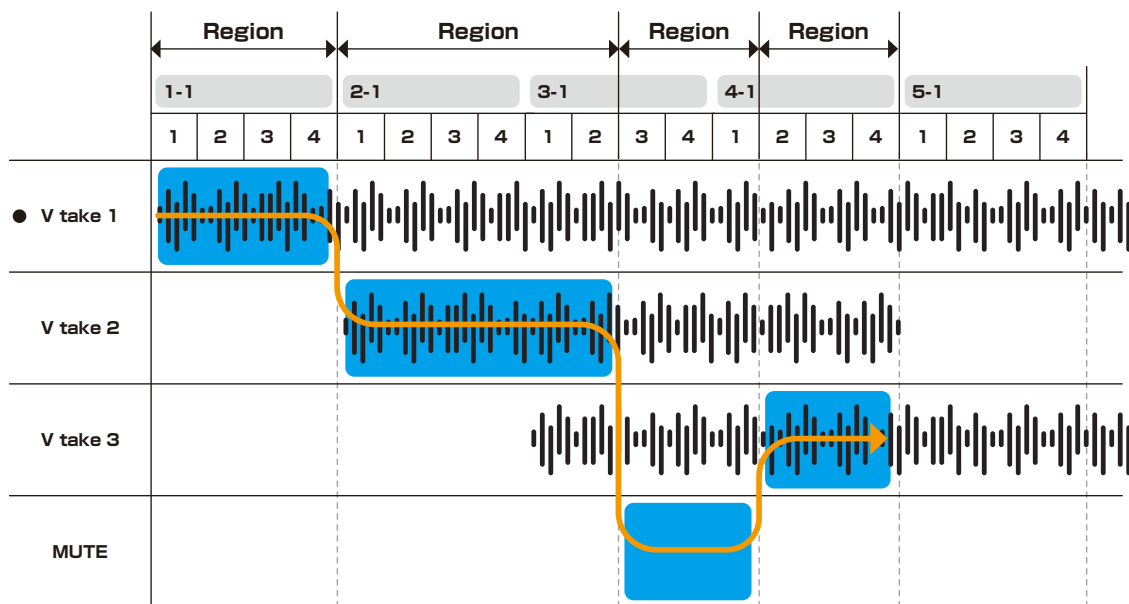

→ V takes played in order



POINT!

- The GLOBAL track is played only during project playback. Please note that the GLOBAL track is not played during scene playback.









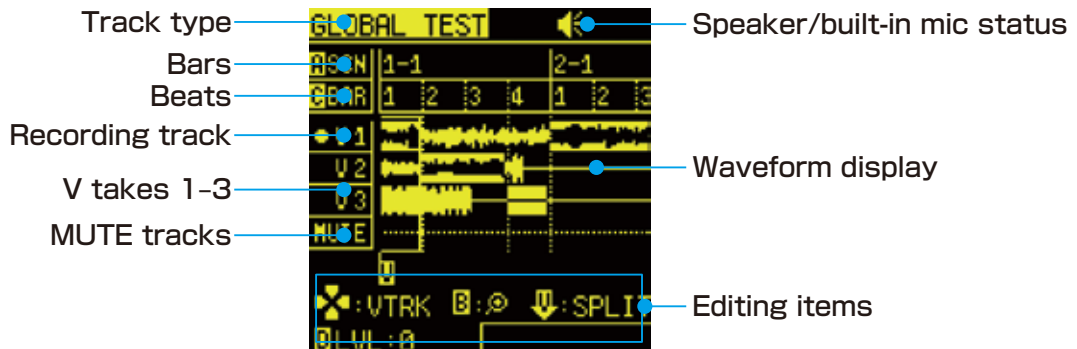



GLOBAL tracks

GLOBAL Screen basic operations

GLOBAL tracks must be enabled for them to be used.

- 1 Select a GLOBAL track clip, press  or , and select **YES**.



Global track editing			
	Move between bars		Play
	Zoom waveform in/out		Adjust selected point precisely
	Move editing selection by beats	 	Split region
	Adjust level		Cancel division
	The input sound is passing through the global track channel	<input type="checkbox"/> TRK 1 <input type="checkbox"/> TRK 2 <input type="checkbox"/> TRK 3	Switch recording track
	Recording standby state		Switch scenes
	Selects take above/below or move by region left/right		

GLOBAL tracks

Recording

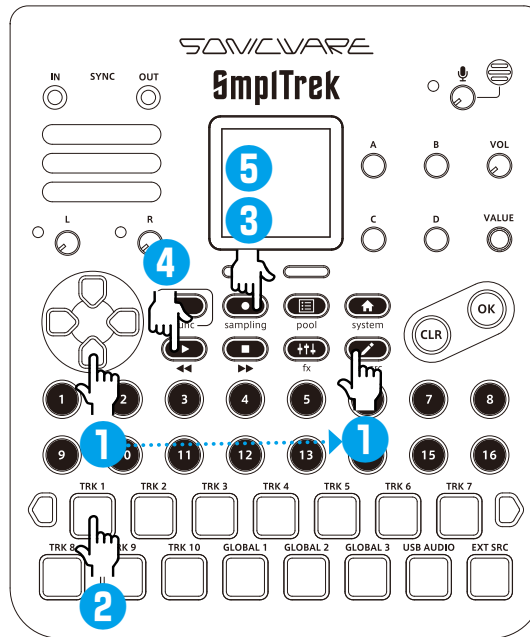

- 1** Select the GLOBAL track clip to use for recording, and press **OK** or **ENTER**.

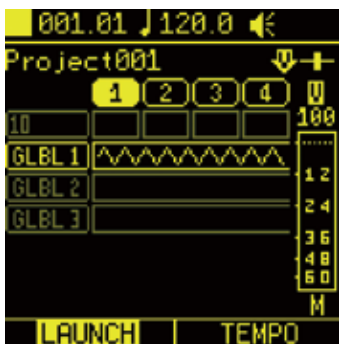

- 2** Press **TRK 1** – **TRK 3** to select the V take to use for recording.





GLOBAL tracks

3 Press  twice to start recording standby.

4 Press  to start recording.

5 Press  to end recording.

Global Track (Recording)	
	Audition state is active. The sound is passing through the global track channel. Use this to practice before recording.
	The unit is in recording standby or recording.

GLOBAL tracks

Splitting regions

- 1 Select the GLOBAL track clip to edit, and press  or .

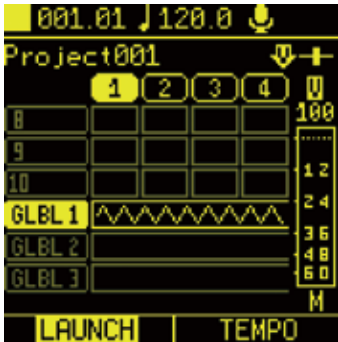

- 2 Turn ,  and  to move to the desired division point.



- 3 Press  or  to split the region.



GLOBAL tracks

Switching take assignments

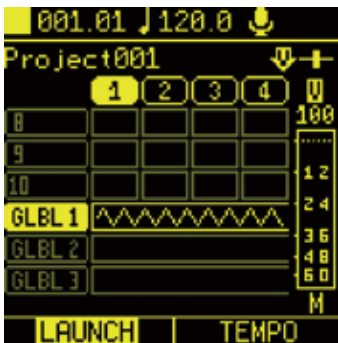

- 1 Select the GLOBAL track clip to edit, and press  or .

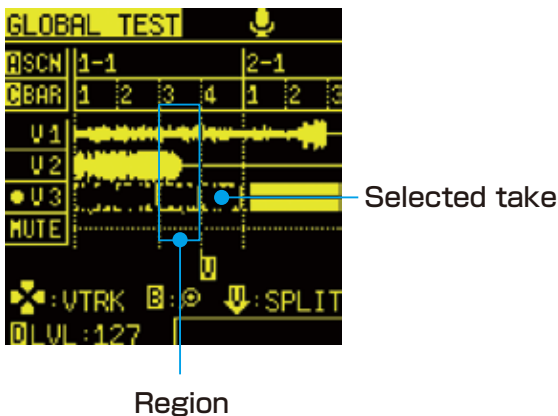

- 2 If necessary, record V takes and split regions beforehand.
(→ P.95 ~ P.97)

- 3 Use   to move to the region with the take to be switched.



- 4 Use   to select the V take (or MUTE track) to use. The color of the selected take waveform is inverted.





GLOBAL tracks

Joining regions

- 1 Select the GLOBAL track clip to edit, and press  or .



- 2 Use   to select the area of a split region.



Split

- 3 Press  to join the selected region with the region before it.



Joined

GLOBAL tracks

Adjusting individual region levels

In addition to switching V take assignments, splitting regions enables precise level adjustments for each region.

- 1 Select the GLOBAL track clip to edit, and press  or .

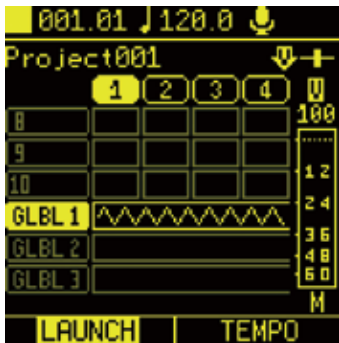

- 2 Use   to select a region to adjust.

- 3 Turn  to adjust the level.



USB AUDIO track

Overview

Using the audio interface function, music can be quickly live-streamed using a connected smartphone, PC or Mac. Audio on the other device can also be played back and sampled.

USB AUDIO track

Connecting a smartphone, PC or Mac to the SmpITrek by USB

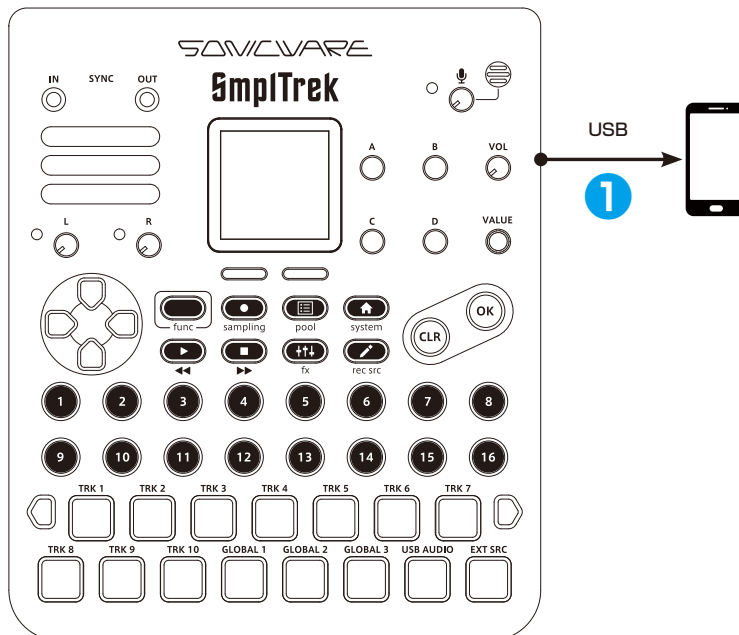

- 1 Connect a smartphone, PC or Mac to the SmpITrek by USB.

USB icon appears



POINT!

- Connecting an iPhone/iPad requires an Apple Lightning to USB Camera Adapter.

USB AUDIO track

Playing audio from a smartphone, PC or Mac

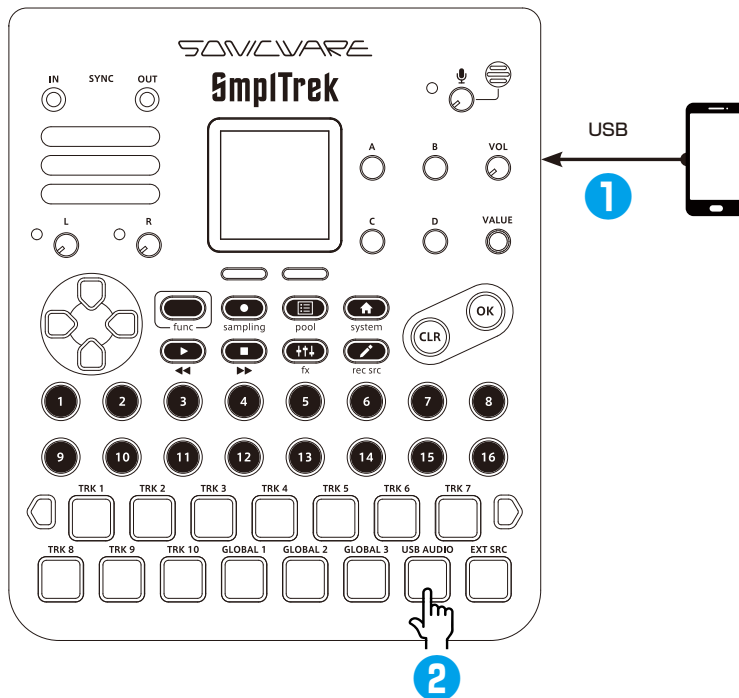

1 Connect a smartphone, PC or Mac to the SmpITrek by USB.

2 Press USB AUDIO .

3 Play the audio on the smartphone, PC or Mac.

POINT!

- The USB AUDIO track level and send level for the SEND FX can be adjusted with the MIXER.

USB AUDIO track

Sampling audio from a smartphone, PC or Mac

1 Press  +  to open the **REC SRC** Screen.

2 Turn  to select USB.

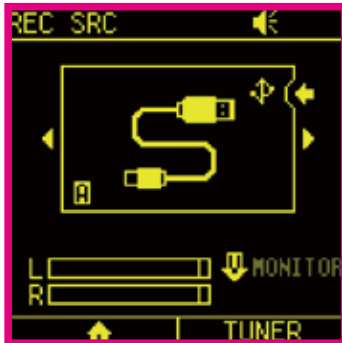

3 Sample it. (→ P.26)

USB AUDIO track

HOLD/GATE

The behavior of the USB AUDIO PAD can be changed.

- 1 Press  +  to open the USB SETTING Screen.



- 2 Turn  to switch between **HOLD** and **GATE**.

HOLD	Press the pad once to enable the USB AUDIO track and begin receiving audio from the smartphone, PC or Mac. Press it again to disable it.
GATE	The USB AUDIO track will be enabled only while the pad is being pressed.

USB AUDIO track

Clearing settings

- 1 Press  +  to open the USB SETTING Screen.



- 2 Press  **CLEAR SETTING**.



- 3 Select **YES**, and press .

EXT SRC

Overview

Using EXT SRC, while playing a project on the SmpITrek, mics or synthesizers, for example, can be connected to the inputs and used for live performance. Audio files can also be played, allowing a SmpITrek project to be faded in while sound effects are being output before a live performance, for example.

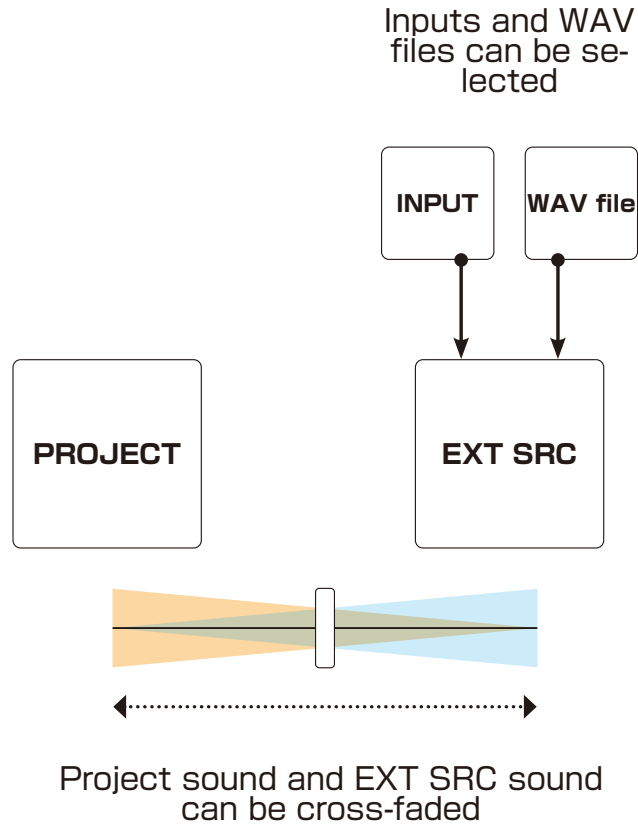

EXT SRC

Setting the input source

- 1 Press  +  to open the EXT SETTING Screen.



- 2 Turn  to switch the **SOURCE**.

INPUT	Audio from the device connected to the inputs will be output.
AUDIO FILE	An audio file will be played.

EXT SRC

Selecting audio files

- 1 Press  +  to open the EXT SETTING Screen.



- 2 Turn  to switch **SOURCE** to **AUDIO FILE**.



- 3 Press  **FILE SELECT**, and select the desired file from the SAMPLE POOL.



EXT SRC

Making audio file settings

- 1 Press  +  to open the EXT SETTING Screen.



- 2 Press the right  **2/2** button to open the second page.



- 3 Set **LOOP** and **LoFi** as necessary.



LOOP	Turn looping on/off
LoFi	Turn the lofi effect on/off

This looping function replays the file from the beginning after reaching the end.

EXT SRC

HOLD/GATE

The behavior of the EXT SRC PAD can be changed.

- 1 Press  +  to open the EXT SETTING Screen.



- 2 Turn  to switch between **HOLD** and **GATE**.





HOLD	Press once to enable the EXT SRC track and begin receiving audio from the smartphone, PC or Mac. Press it again to disable it.
GATE	The EXT SRC track will be enabled only while the pad is being pressed.

EXT SRC

Cross-fading the external source (EXT SRC) and the project sound

The sound input as the EXT SRC can be output with project playback. The level balance can be set for this.

- 1 On the Home Screen, press  VALUE to open a pop-up.
- 2 Turn  VALUE to adjust the balance between the project and the external input.



PRJ	This increases the volume of the project.
EXT	This increases the volume of the external input.

EXT SRC

Clearing settings

- 1 Press  +  to open the EXT SETTING Screen.



- 2 Press  **CLEAR**.

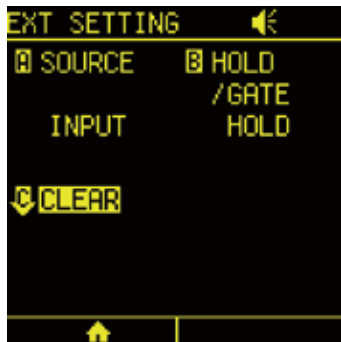



- 3 Select **YES**, and press .

Other track and clip settings

LoFi (LOOP, SHOT)

Turning on LoFi changes the playback sampling quality of the clip to **24kHz/12-bit**.

- 1 Select the clip to change, and press  or  to open the Editing Screen.

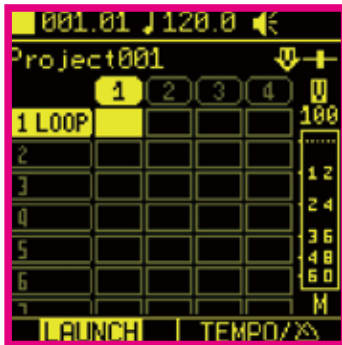

- 2 Press  again to open the SETTING Screen, and select **SAMPLE SETTING**.



- 3 Turn  **LoFi** to change it.



Other track and clip settings

Adjusting levels for individual clips (LOOP tracks)

Levels can be adjusted for individual clips in LOOP tracks.

- 1 Select the clip to adjust, and press  or  to open the Editing Screen.

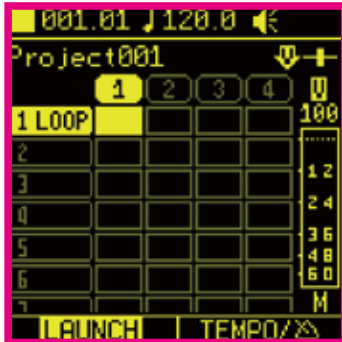

- 2 Press  again to open the SETTING Screen, and select **SAMPLE SETTING**.



- 3 Turn  **A LEVEL** to adjust it.



Other track and clip settings

LoFi (INST, GLOBAL)

Turning on LoFi changes the playback sampling quality of the track to **24kHz/12-bit**.

- 1 Press  +  for the desired track to open the SETTING Screen.

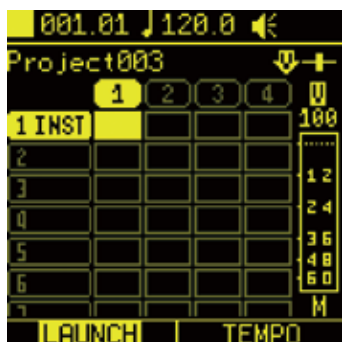



- 2 Turn  **LoFi** to change it.



Other track and clip settings

PITCH (SHOT)

1 Select the clip to change, and press  or  to open the Editing Screen.



2 Press  again to open the SETTING Screen, and select **SAMPLE SETTING**.



3 Turn  **PITCH** to adjust it.



Other track and clip settings

PITCH (INST)

- 1 Press  +  for the desired track to open the SETTING Screen.

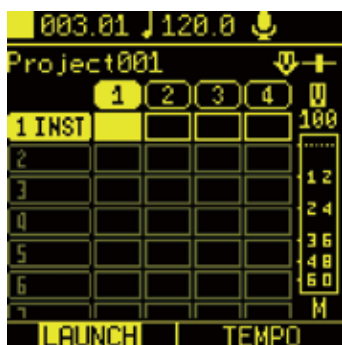

- 2 Turn  **PITCH** to adjust it.









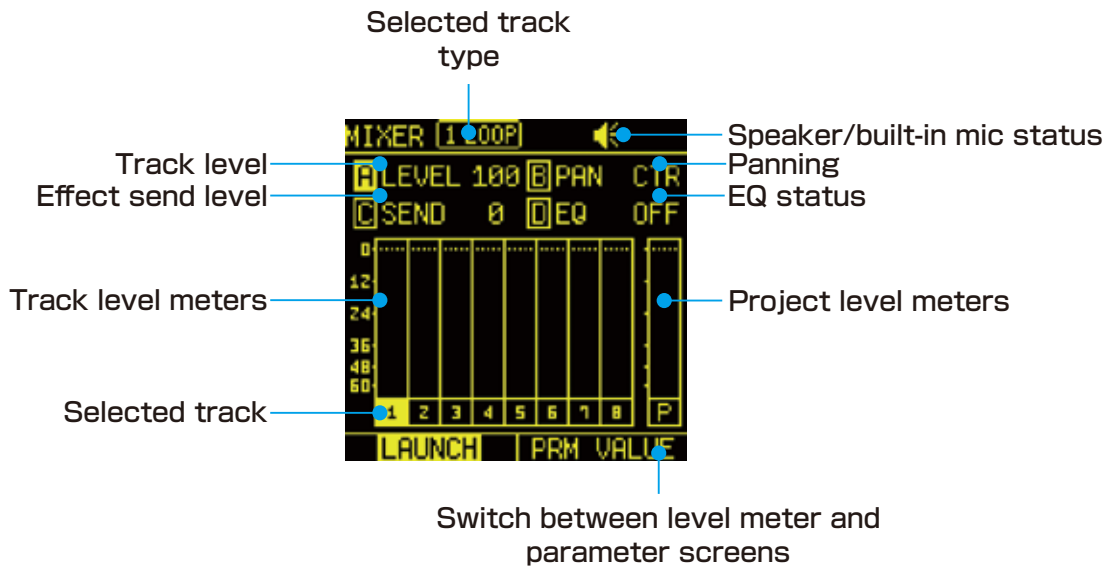





Mixer

Basic mixer screen operation (level meters)

Press .











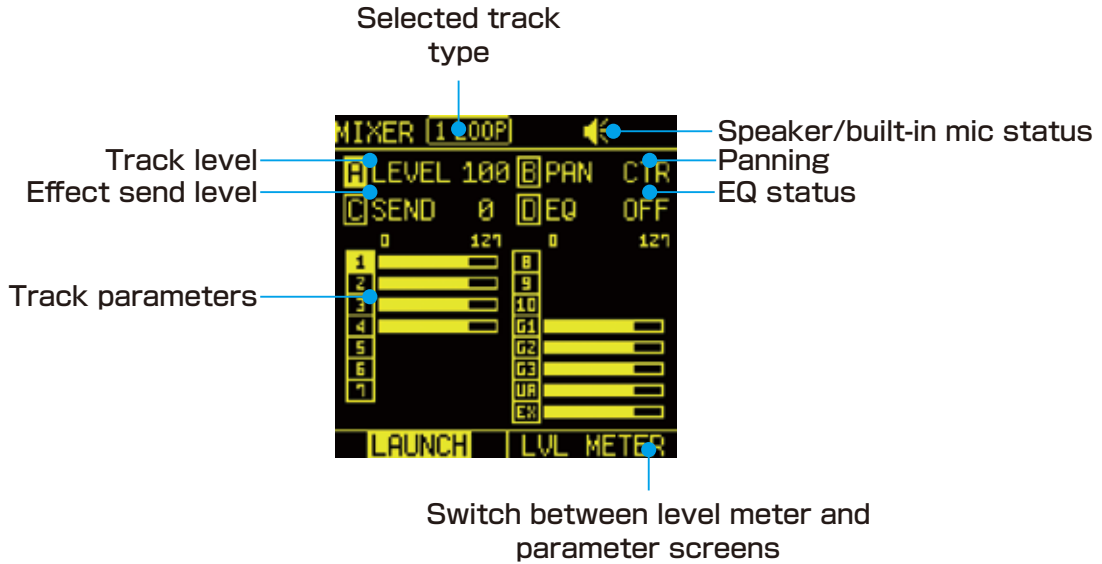



Mixer (level meters)			
	Track/project level		Open Parameter Screen
	Panning		Open Parameter Screen
	Effect send level		Open Parameter Screen
	EQ adjustment		Open Parameter Screen
	Project level		Track selection
 + 	Mute/unmute tracks		

Mixer

Basic mixer screen operation (PRM VALUE)

Press the right  **PRM VALUE** button or  A –  D to open the PRM VALUE Screen.



Mixer (level meters)			
 A	Track level	 VALUE	Project level
 B	Panning		Track selection
 C	Effect send level	After pressing  D, press 	Open EQ editing screen
 D	Switch EQ type/Adjust EQ editing item		
 D	Switch EQ editing item	 + 	Mute/unmute tracks

Mixer

Making specific EQ settings



- 1 Press  to open the Mixer Screen.



- 2 After pressing  EQ, press  to open the EQ Settings Screen.



- 3 Set each item.





EQ settings	
 A	Change EQ type
 C	Adjust EQ frequency
 D	Adjust gain of frequency

Mixer

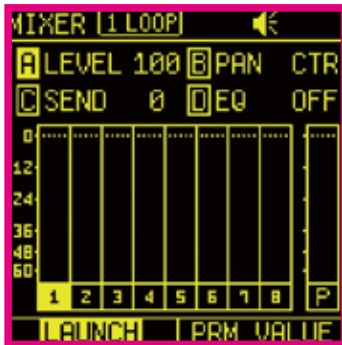
Muting tracks

- 1 Press  to open the Mixer Screen.



- 2 Press  +  for the track to be muted.
Press  +  again to unmute it.

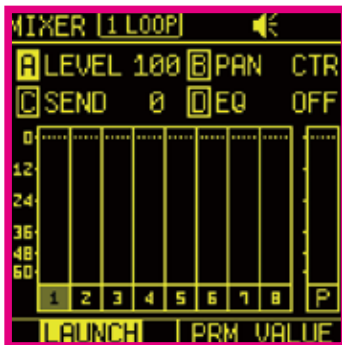

Effects

Insert effects

- 1 Press **func** + **fx** to open the EFFECTS Screen.
- 2 Select **INSERT**.

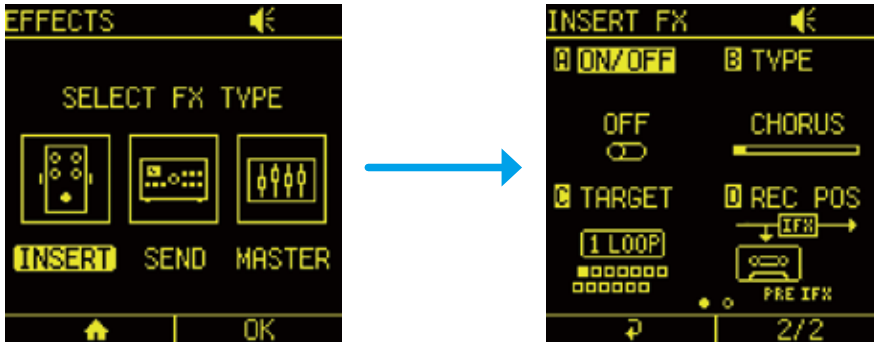

- 3 Adjust the items on the settings screen that opens.





INSERT FX (1/2)			
	ON/OFF	Turn the effect on/off	
	TYPE	Change the effect type	
	TARGET	Select the track or input to use the effect on	
	REC POS		Sound is sampled before effects are applied
			Sound is sampled after effects are applied

INSERT FX (2/2)
- items depend on selected effect

POINT!

- When the **TARGET** is **INPUT**, turn on the **EXT SRC** to check the effect sound. The insert effect is not applied to the sound monitored when monitoring is on for the **REC SRC**.

Effects

Insert effects list				
Effect name	 A	 B	 C	 D
CHORUS	RATE	DEPTH	MIX	
FLANGER	RATE	DEPTH	FEEDBACK	
PHASER	RATE	STAGE	MIX	INVERT
DELAY	RATE	FEEDBACK	BPM SYNC	BALANCE
ANALOG DELAY	TIME	FEEDBACK	BPM SYNC	BALANCE
VIBRATO	RATE	DEPTH	BPM SYNC	
AUTO WAH	SENS	DEPTH	Q	
TREMOLO	RATE	DEPTH	BPM SYNC	
RING MOD	MOD TYPE	RATE	DEPTH	MIX
CRUSHER	SAMPLE RATE	CUTOFF	BALANCE	
AUTO PAN	MOD TYPE	RATE	BPM SYNC	DEPTH
ISOLATOR	FREQ	BALANCE		
TILT EQ	FREQ	BALANCE		
STMP COMP	SENS	ATTACK	LEVEL	
RACK COMP	RATIO	COMP	ATTACK	GAIN
CLEAN AMP *	GAIN	TONE	LEVEL	
CRUNCH AMP *	GAIN	TONE	LEVEL	
ROCK AMP *	GAIN	TONE	LEVEL	
METAL AMP *	GAIN	TONE	LEVEL	
BASS AMP *	GAIN	TONE	LEVEL	

*WHEN THE INSERT EFFECT IS ON AND THE TYPE IS AN AMP, THE MASTER EFFECT WILL BE DISABLED (→ P.128).

Effects

Send effects

- 1 Press **func** + **fx** to open the EFFECTS Screen.
- 2 Select **SEND**.



- 3 Adjust the items on the settings screen that opens.







- 4 On the Mixer Screen, turn **⊗c** for each track to adjust their **SEND** levels.

Send Effects (1/2)		
⊗A	ON/OFF	Turn the effect on/off
⊗B	TYPE	Change the effect type

Send Effects (2/2)	
⊗A – ⊗D	items depend on selected effect

Effects

Send effects list				
Effect name	 A	 B	 C	 D
SEND DLY	TIME	BPM SYNC	FEEDBACK	MIX
PINGPONG	TIME	BPM SYNC	FEEDBACK	MIX
RVS DLY	TIME	BPM SYNC	FEEDBACK	MIX
TAPE ECHO	TIME	BPM SYNC	FEEDBACK	MIX
ROOM			MIX*	
PLATE			MIX*	
HALL			MIX*	
STADIUM			MIX*	
TUNNEL			MIX*	
INFINITY			MIX*	
SC COMP	THRESHOLD	RATIO	ATTACK	RELEASE

*  ON SEND FX PAGE 1

Effects

Side-chain compression (SC COMP)

- 1 Press **func** + **fx** to open the EFFECTS Screen.
- 2 Select **SEND**.
- 3 Turn **B**, and select **SC COMP** as the TYPE.



- 4 Turn **C** to select the track to use as the trigger for side-chain compression.

POINT!

- The compressor will be applied when triggered to all tracks that have SEND set to any value other than **0** on the Mixer Screen

Effects

Master effects

- 1 Press **func** + **fx** to open the EFFECTS Screen.
- 2 Select **MASTER**.

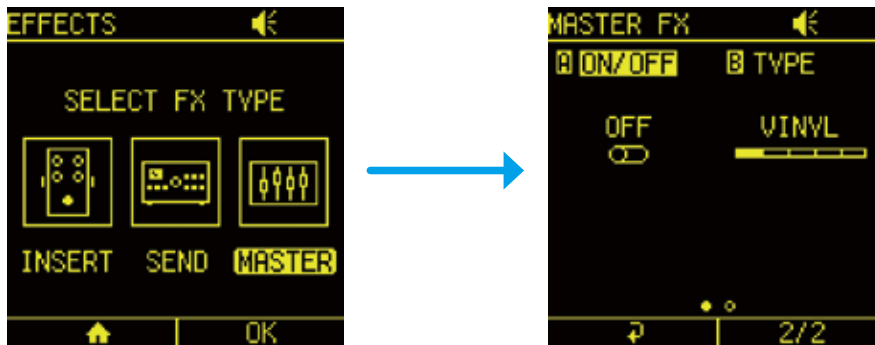

- 3 Adjust the items on the settings screen that opens.





Send Effects (1/2)		
	ON/OFF	Turn the effect on/off
	TYPE	Change the effect type

Send Effects (2/2)	
-	items depend on selected effect

POINT!

- When the insert effect is on and the type is an amp, the master effect will be disabled even if it is on.
Turn off the insert effect. (→ P.123)

Effects

Master effects list				
Effect name	 A	 B	 C	 D
VINYL	FLUTTER	BAND WIDTH	NOISE	PRE GAIN
CASSETTE	FLUTTER	CUTOFF	NOISE	PRE GAIN
M.B. COMP	Band 1	Band 2	Band 3	Level
EQ+LIMITER	Band 1	Band 2	Band 3	LIMITER
MAXIMIZER	THRESHOLD			

Automation

Automation is a function that prepares various parameters in individual clips on tracks to be changed with the desired timing.

Using automation enables an even greater range of sound creation. For example, volume can be increased gradually and panning can be moved for specific pitches and samples to change their stereo positions.

Automation can be used on **SHOT**, **INST**, **DRUM** and **MIDI** tracks.

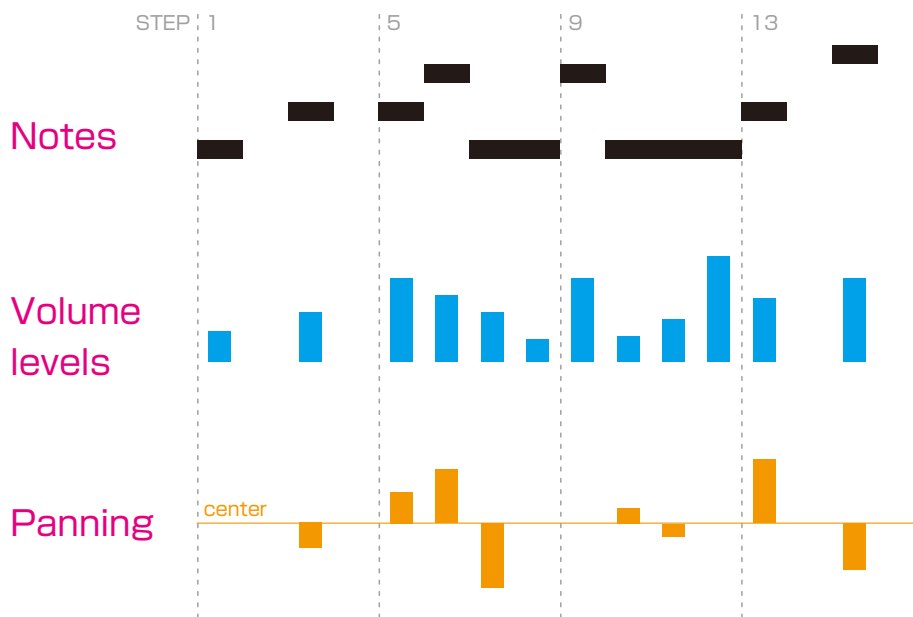

Automation

Basic automation procedure

- 1 Select the clip to automate, and press .

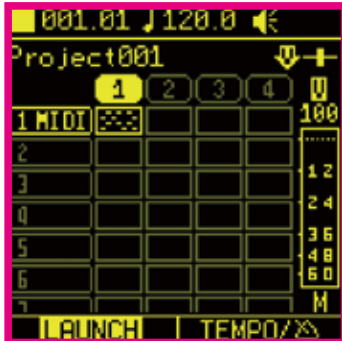

- 2 Press the right   button to open the automation screen.

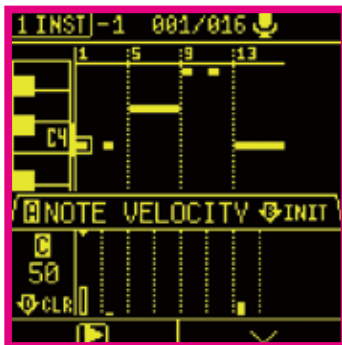



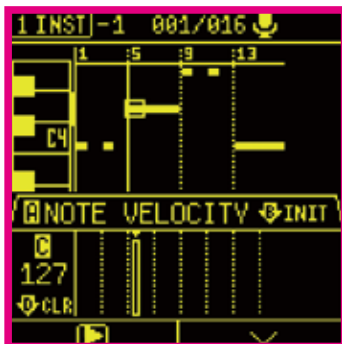

- 3 Use  to move the cursor to the step where you want to change automation.



- 4 Use  -  to set each item.

Automation

Automation	
 A	Select automation parameter
 B	Clear current automation parameter (all steps)
 C	Adjust automation parameter for current step
 D	Clear currently selected automation parameter (current step only)

Automation parameter list				
	SHOT track	INST track	DRUM track	MIDI track
NOTE VELOCITY	<input type="radio"/>	<input type="radio"/>	<input type="radio"/>	<input type="radio"/>
MICRO TIMING	<input type="radio"/>	<input type="radio"/>	<input type="radio"/>	<input type="radio"/>
LEVEL	<input type="radio"/>	<input type="radio"/>	<input type="radio"/>	
PAN	<input type="radio"/>	<input type="radio"/>	<input type="radio"/>	
SEND	<input type="radio"/>	<input type="radio"/>	<input type="radio"/>	
PLAY LENGTH	<input type="radio"/>			
PITCH	<input type="radio"/>			
CC A				<input type="radio"/>
CC B				<input type="radio"/>
CC C				<input type="radio"/>
CC D				<input type="radio"/>

Automation

Automation parameters (all track types)	
NOTE VELOCITY	Velocity strength
MICRO TIMING	Sound output timing
LEVEL	Volume (excluding MIDI tracks)
PAN	Left-right position (excluding MIDI tracks)
SEND	Effect send level (excluding MIDI tracks)

Automation (SHOT tracks)	
PLAY LENGTH	Time sound output continues
PITCH	Sample volume

Automation (MIDI tracks)	
CC A	Transmission of control change data to external MIDI devices (0 - 127)
CC B	
CC C	
CC D	

Editing samples

Chopping (automatic slicing)

1 Press **func** + **pool**, and select  **SAMPLE** to open the SAMPLE POOL Screen.

2 Select the desired sample, press **OK**, and select **CHOP**.

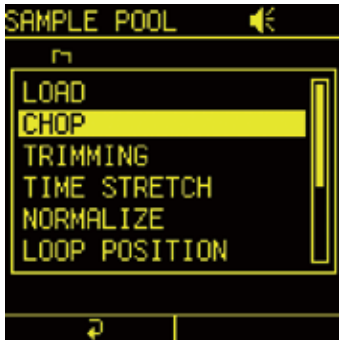





3 On the CHOP/SLICE Screen, press **OK**.



4 Press the  LED pads to check the slices assigned to them. (This plays the slices.)

Editing samples

5 Turn  VALUE to adjust the sensitivity of automatic slicing.

Chop (Auto Slice)	
 A	Select slice
 B	Move slice
 c	Move waveform display
 D	Zoom waveform display in/out
 VALUE	Adjust sensitivity

Editing samples

Chopping (manual slicing)

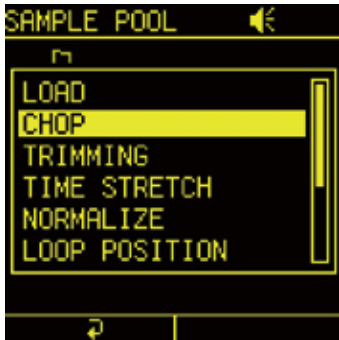

1 Press **func** + **pool**, and select  **SAMPLE** to open the SAMPLE POOL Screen.

2 Select the desired sample, press **OK**, and select **CHOP**.



3 On the CHOP/SLICE Screen, press the left  **TO MANUAL** button.









4 Press , and while playing the sample, press **OK** at the desired position or press an LED pad  to slice.



Editing samples

5 Use the following to adjust slices precisely.

Chopping	
 A	Select slice
 B	Move slice
 c	Move waveform display
 D	Zoom waveform display in/out
 VALUE	Move slice position
 OK	Add slice
 CLR	Clear slice

Editing samples

Trimming



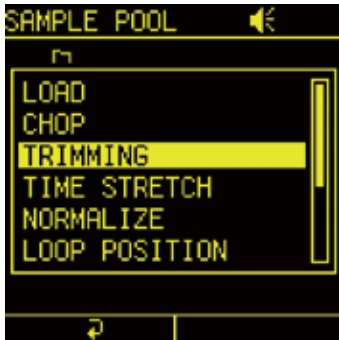





- 1 Press **func** + **pool**, and select  **SAMPLE** to open the SAMPLE POOL Screen.
- 2 Select the desired sample, press **OK**, and select **TRIMMING**.



- 3 Set the interval used for the sample.
At the BPM BARS position, press **VALUE** to select it. Then, turn **VALUE** to change the interval setting method (**BPM BARS**, **BPM NOTE STEP** or **AB POINT**).



Editing samples

Trimming	
 A	Start point in sample
 B	End point in sample (AB POINT)
 C	Move zoomed waveform display
 D	Zoom waveform display
 VALUE	Select/change BPM items
 VALUE	Confirm BPM item selection
Left 	Quit
Right 	Open next menu page

- 4** Press the right  **EXEC** button to execute the changes. The SAMPLE POOL Screen will reopen.

POINT!

- Executing will save a file named “original file name_ **trim.wav**” . The original file will not be overwritten.

Editing samples

Time stretching

- 1 Press **func** + **pool**, and select  **SAMPLE** to open the SAMPLE POOL Screen.
- 2 Select the desired sample, press **OK**, and select **TIME STRETCH**.

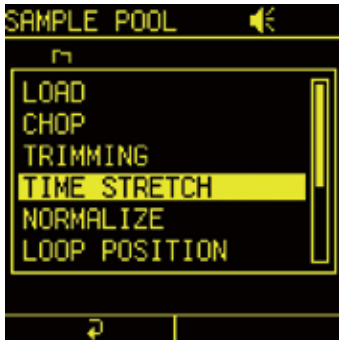













- 3 Select the type of time stretching.





MELODIC	Algorithm suitable for melodies and similar phrases
RHYTHMIC	Algorithm suitable for drums and other phrases capturing short sounds

Editing samples

Time Stretch (MODE - BARS)		
 A	MODE	BARS mode
 B	BPM	Change tempo
 C	TIMESIG	Change time signature
 D	BARS	Change number of bars
Left 	BACK	Return to previous screen
Right 	EXEC	Execute

Time Stretch (MODE - STEPS)		
 A	MODE	STEPS mode
 B	BPM	Change tempo
 C	NOTE	Length of note
 D	STEPS	Number of steps
Left 	BACK	Return to previous screen
Right 	EXEC	Execute

Time Stretch (MODE - TIME)		
 A	MODE	TIME mode
 B	TIME%	Adjust by percentage

POINT!

- Executing will save a file named “original file name_ **ts.wav**” . The original file will not be overwritten.

Editing samples

Normalizing

- 1 Press **func** + **pool**, and select  **SAMPLE** to open the SAMPLE POOL Screen.
- 2 Select the desired sample, press **OK**, and select **NORMALIZE**.

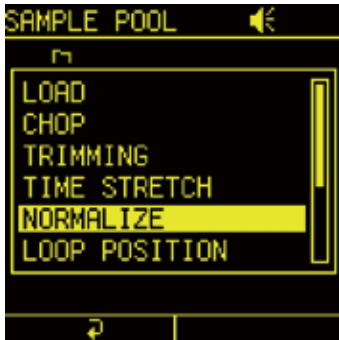

- 3 Select the type of normalization

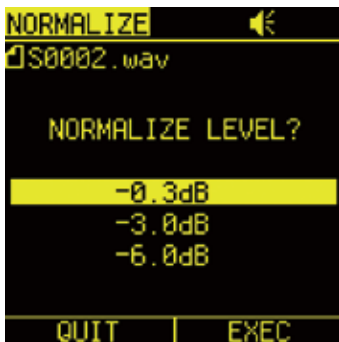

- 0.3dB	Normalize so the peak becomes - 0.3dB
- 3.0dB	Normalize so the peak becomes - 3.0dB
- 6.0dB	Normalize so the peak becomes - 6.0dB

POINT!

- Executing will save a file named “original file name_**norm.wav**” . The original file will not be overwritten.

Editing samples

Mono mixing

1 Press **func** + **pool**, and select  **SAMPLE** to open the SAMPLE POOL Screen.

2 Select the desired sample, press **OK**, and select **MONO**.

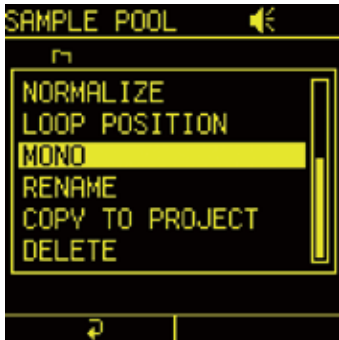

3 Select the MONO type.



L ONLY	Use only left channel sound
MONO MIX	Make stereo channels mono
R ONLY	Use only right channel sound

POINT!

- Executing will save a file named “original file name_ **mono.wav**”. The original file will not be overwritten.

Editing samples

Renaming samples

1 Press **func** + **pool**, and select  **SAMPLE** to open the SAMPLE POOL Screen.

2 Select the desired sample, press **OK**, and select **RENAME**.



3 Change the name, and press the right **OK** button.



Editing samples

Copying samples to projects

- 1 Press **func** + **pool**, and select  **SAMPLE** to open the SAMPLE POOL Screen.
- 2 Select the desired sample in the POOL folder, press **OK**, and select **COPY TO PROJECT**.



- 3 Select **YES**, and press **OK**.

Editing samples

Copying samples to the sample pool

- 1 Press **func** + **pool**, and select  **SAMPLE** to open the SAMPLE POOL Screen.
- 2 Select the desired sample in the PROJECT folder, press **OK**, and select **COPY TO POOL**.

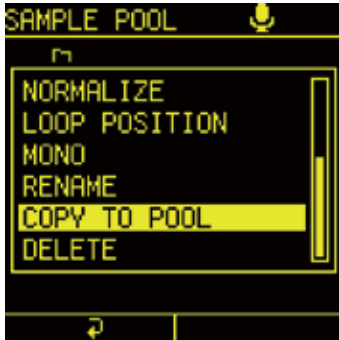

- 3 Select **YES**, and press **OK**.

Editing samples

Deleting samples

1 Press **func** + **pool**, and select  **SAMPLE** to open the SAMPLE POOL Screen.

2 Select the desired sample, press **OK**, and select **DELETE**.





3 Select **YES**, and press **OK**.

POINT!

- Be careful because deletion cannot be undone.

Project menu

Copying projects and saving with new names (SAVE AS)

- 1 Press  to open the PROJECT MENU Screen.
- 2 Select **SAVE AS**, and press .



- 3 Select an **(EMPTY)** slot, and press .





- 4 Input the name, and press the right  **OK** button.



Project menu

Renaming projects

- 1 Press  to open the PROJECT MENU Screen.
- 2 Select **RENAME**, and press .



- 3 Change the name, and press the right  **OK** button.



Project menu

Deleting projects

1 Press  to open the PROJECT MENU Screen.

2 Select **DELETE**, and press .



3 Select **YES**, and press .



POINT!

- Be careful because deletion cannot be undone.

Project menu

Mixing down

1 Press  to open the PROJECT MENU Screen.

2 Select **AUDIO EXPORT**, and press .



3 Select **MIX DOWN**, and press .



4 Input the name, and press the right  **OK** button.





POINT!

- The mixdown file will be created in the following location: card > SmpITrek > Project > project folder name > Audio > MixDown folder.

Project menu



Exporting stem files

- 1 Press  to open the PROJECT MENU Screen.
- 2 Select **AUDIO EXPORT**, and press .



- 3 Select **INDIVIDUAL TRACKS**, and press .



- 4 Press , select the tracks to export, and press the right  OK button.

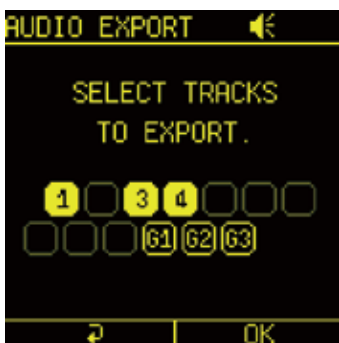

POINT!

- The stem file will be created in the following location: card > Sm-plTrek > Project > project folder name > Audio > Stem folder.

Project menu

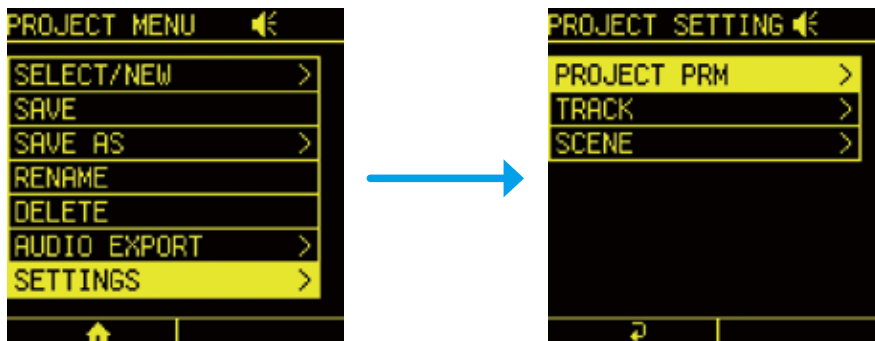

Setting project parameters

- 1 Press  to open the PROJECT MENU Screen.
- 2 Select **SETTING** > **PROJECT PRM**.

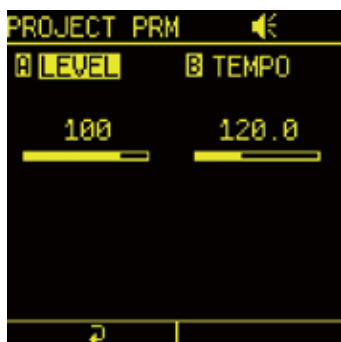

- 3 Set each item.



PROJECT PRM		
 A	Level	Project volume level
 B	TEMPO	Project tempo

Project menu

Changing LED pad colors (TRACK COLOR)

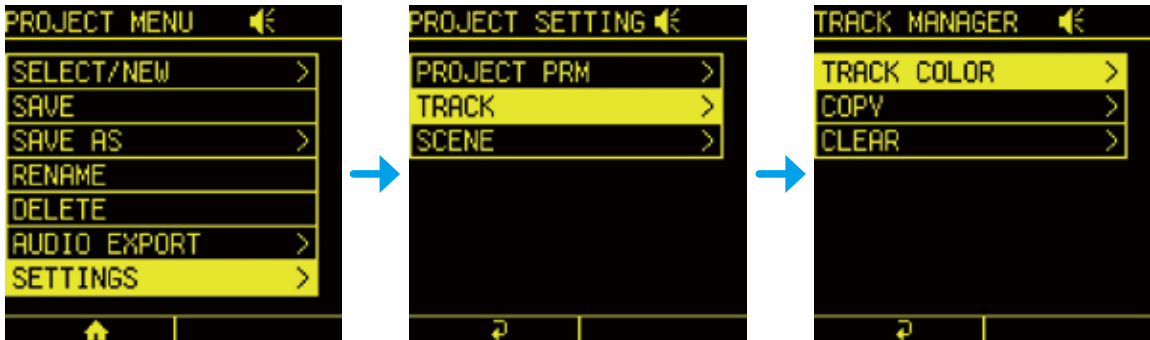

1 Press  to open the PROJECT MENU Screen.

2 Select **SETTING > TRACK > TRACK COLOR**.



3 Set each item.







Track Color	
 A	Track selected for color changing
 B	Color type

Project menu

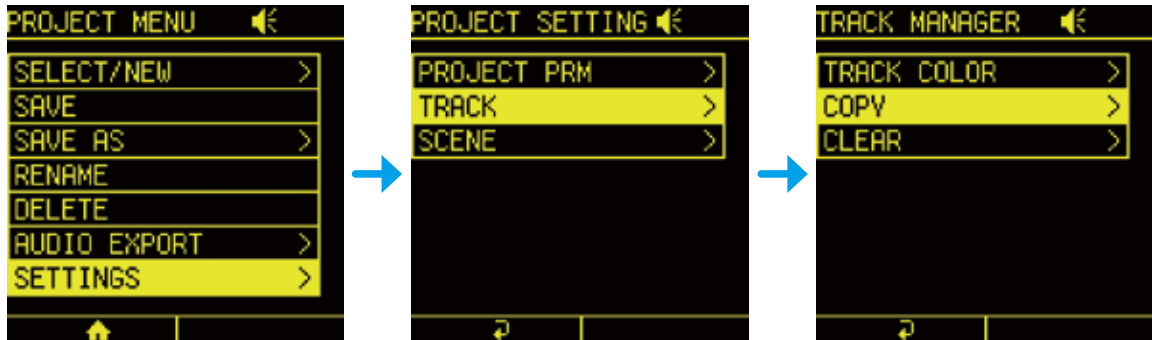

Copying tracks (COPY)

- 1 Press  to open the PROJECT MENU Screen.
- 2 Select **SETTING > TRACK > COPY**.



- 3 Use  and  to select the copy source and destination tracks, and press  to execute.



Copy	
 A	Copy source
 c	Copy destination

Project menu

Clearing tracks (CLEAR)

1 Press  to open the PROJECT MENU Screen.

2 Select **SETTING > TRACK > CLEAR**.



3 Select tracks to clear, and press .



Project menu

Changing how many times scenes repeat (REPEAT)



1 Press  to open the PROJECT MENU Screen.

2 Select **SETTING > SCENE > REPEAT**.





3 Adjust each item





Scene Repeat	
 A	Scene selection
 B	Number of repetitions

Project menu



Copying scenes (COPY)

- 1 Press  to open the PROJECT MENU Screen.
- 2 Select **SETTING** > **SCENE** > **COPY**, and press .



- 3 Use  and  to select the copy source and destination scenes, and press  to execute.



Copy Scene	
 A	Copy source scene selection
 c	Copy destination scene

Project menu

Clearing scenes (CLEAR)

1 Press  to open the PROJECT MENU Screen.

2 Select **SETTING > SCENE > CLEAR**.



4 Select the scene , and press  to clear it.



POINT!

- Be careful because cleared scenes cannot be restored.

Drum kits

Editing

- 1 Press **func** + **pool**, and select  **KIT** to open the KIT POOL Screen.
- 2 To edit a selected drum kit, press **OK**, and select **EDIT**. To create a new drum kit, press the right **NEW** button.

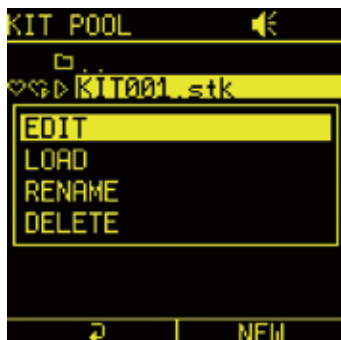

- 3 Select menu items as necessary, and press **OK**.



INST PRM	Assign sampled sounds to LED pads, and adjust their levels and panning, for example
KIT PRM	Set the KIT LEVEL and turn LoFi ON/OFF
PAD COLOR	Set LED pad colors
SEND FX FOR CHECK	Use this to check effects applied to the kit

Drum kits

Adjusting individual instruments on LED pads (INST PRM)

- 1 Press **func** + **pool**, and select  **KIT** to open the KIT POOL Screen.
- 2 Select the desired drum kit, press **OK**, and select **EDIT**.



- 3 Select **INST PRM**, and press **OK**.







- 4 Select the LED pad to be set and change each item.







POINT!



- The following table shows the maximum length in seconds of samples that can be assigned to each instrument. Samples longer than the maximum number of seconds can be selected, but parts after this length will not be played back.

Mono	2.73 seconds
Stereo	1.36 seconds

Drum kits

Inst Prm (1/3)		
 A	FILE SELECT	Assign a sample from the SAMPLE POOL
 C	LEVEL	Level adjustment
 D	PAN	PAN adjustment
Left 		Return to previous menu
Right 		Open next page

Inst Prm (2/3)		
 A	FX SEND	Adjust effect send amount
 B	PITCH	Adjust pitch
 C	SLOPE	Adjust attack and release
 D	REVERSE	Turn reverse playback on/off
Left 		Open previous page
Right 		Open next page

Inst Prm (3/3)		
 A	CHOKE	<p>OFF, 0-6</p> <p>Instruments can be grouped by setting the same number to multiple pads.</p> <p>When an LED pad assigned to a choke group is pressed, before the sound of that pad is output, sounds will be muted for the other LED pads in the group of the same number.</p> <p>For example, by giving closed and open hi-hats the same group number, the two sounds will not overlap unnaturally.</p>
Left 		Open previous page

Drum kits

Adjusting drum kit levels and LoFi settings (KIT PRM)

- 1 Press **func** + **pool**, and select **KIT** to open the KIT POOL Screen.
- 2 Select the desired drum kit, press **OK**, and select **EDIT > KIT PRM**.

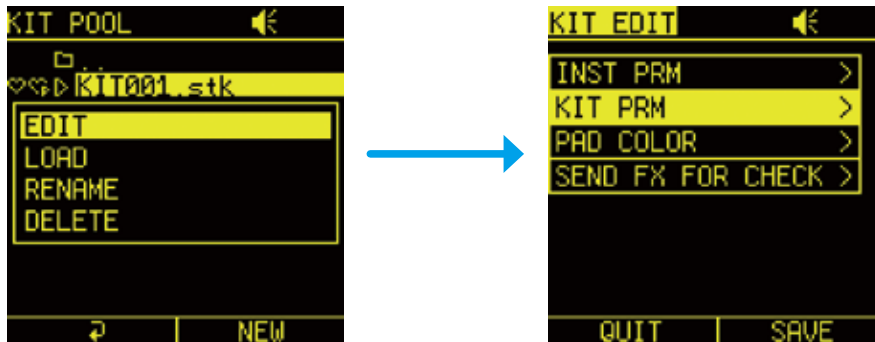

- 3 Set each item.



Kit Prm		
A	Level	Adjust the kit level
B	LoFi	Turn the lofi effect on/off

Drum kits

Adjusting drum kit LED pad colors (PAD COLOR)

- 1 Press **func** + **pool**, and select **KIT** to open the KIT POOL Screen.
- 2 Select the desired drum kit, press **OK**, and select **EDIT > PAD COLOR**.

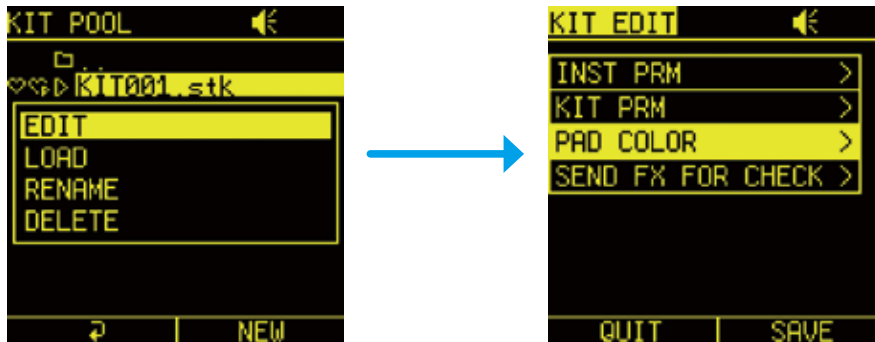

- 3 Use **□** or **VALUE** to select the track to change, and turn **A** to change the color.



Drum Pad Color		
A	COLOR	30 pad colors can be selected

Drum kits

Checking drum kit sounds with reverb (SEND FX FOR CHECK)



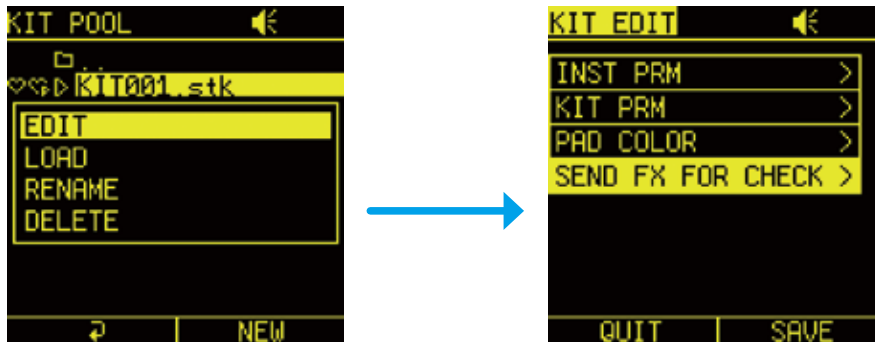



- 1 Press **func** + **pool**, and select **KIT** to open the KIT POOL Screen.
- 2 Select the desired drum kit, press **OK**, and select **EDIT > SEND FX FOR CHECK**.









- 4 Set each item as necessary.



Drum kits

Kit Send FX (1/2)		
 A	ON/OFF	Turn the send effect on/off
 B	SEND	Adjust effect send amount
 C	TYPE	Change the effect type
 D	TEMPO/MIX	Tempo or effect mix level (depends on TYPE)
Left 		Return to previous menu
Right 		Open next page

Kit Send FX (2/2)		
 A	Depends on TYPE	Depends on TYPE
 B		
 C		
 D		
Left 		Open previous page
Right 		Open next page

Drum kits

Deleting drum kits (DELETE)

- 1 Press **func** + **pool**, and select  **KIT** to open the KIT POOL Screen.
- 2 Select the desired drum kit, press **OK**, and select **DELETE**.



- 3 Select **YES**, and press **OK**.



POINT!

- Be careful because deleted kits cannot be restored.

Drum kits

Renaming drum kits

- 1 Press **func** + **pool**, and select  **KIT** to open the KIT POOL Screen.
- 2 Select the desired drum kit, press **OK**, and select **RENAME**.

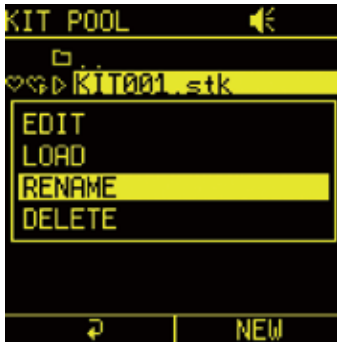

- 3 Change the name, and press the right **OK** button.



Audio interface

By connecting a smartphone or PC/Mac and using the audio interface functions, you can quickly live stream music you have made.

In addition, the SmpITrek can output and sample audio from smartphones, PCs and Macs.

Connecting as an audio interface

- 1 Connect the SmpITrek USB port to a smartphone or PC/Mac. A USB icon will be shown when connected.

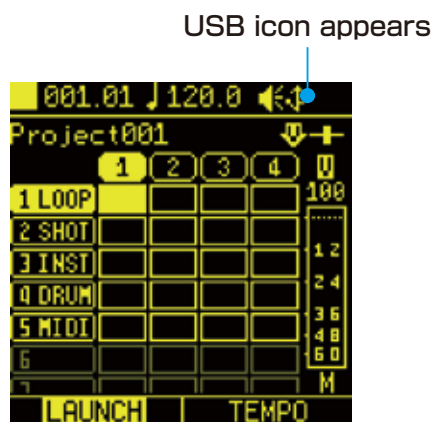



POINT!

- Connecting an iPhone/iPad requires an Apple Lightning to USB Camera Adapter.
- The audio resolution is 48kHz/16-bit.
- Sampling instructions (→ P.104)
- Output instructions (→ P.103)

Quantization

Setting quantization

This quantization sets the start timing of track playback and recording when LED pads and  are pressed.

1 Press  +  to open the SYSTEM MENU Screen.

2 Select **QUANTIZE**, and press .



3 Turn A to set it.



1/4 BAR	Playback and recording start with quarter-note timing
1/2 BAR	Playback and recording start with half-note timing
1 BAR	Playback and recording start with 1-bar timing
2 BAR	Playback and recording start with 2-bar timing
SCENE	Playback and recording start with scene timing

Clock synchronization with external devices

Multiple devices, including external synthesizers and drum machines, can be connected to the MIDI and SYNC connectors, allowing them to be synchronized and used together.

Connecting with other devices

- 1 Connect other device to the MIDI and SYNC connectors.

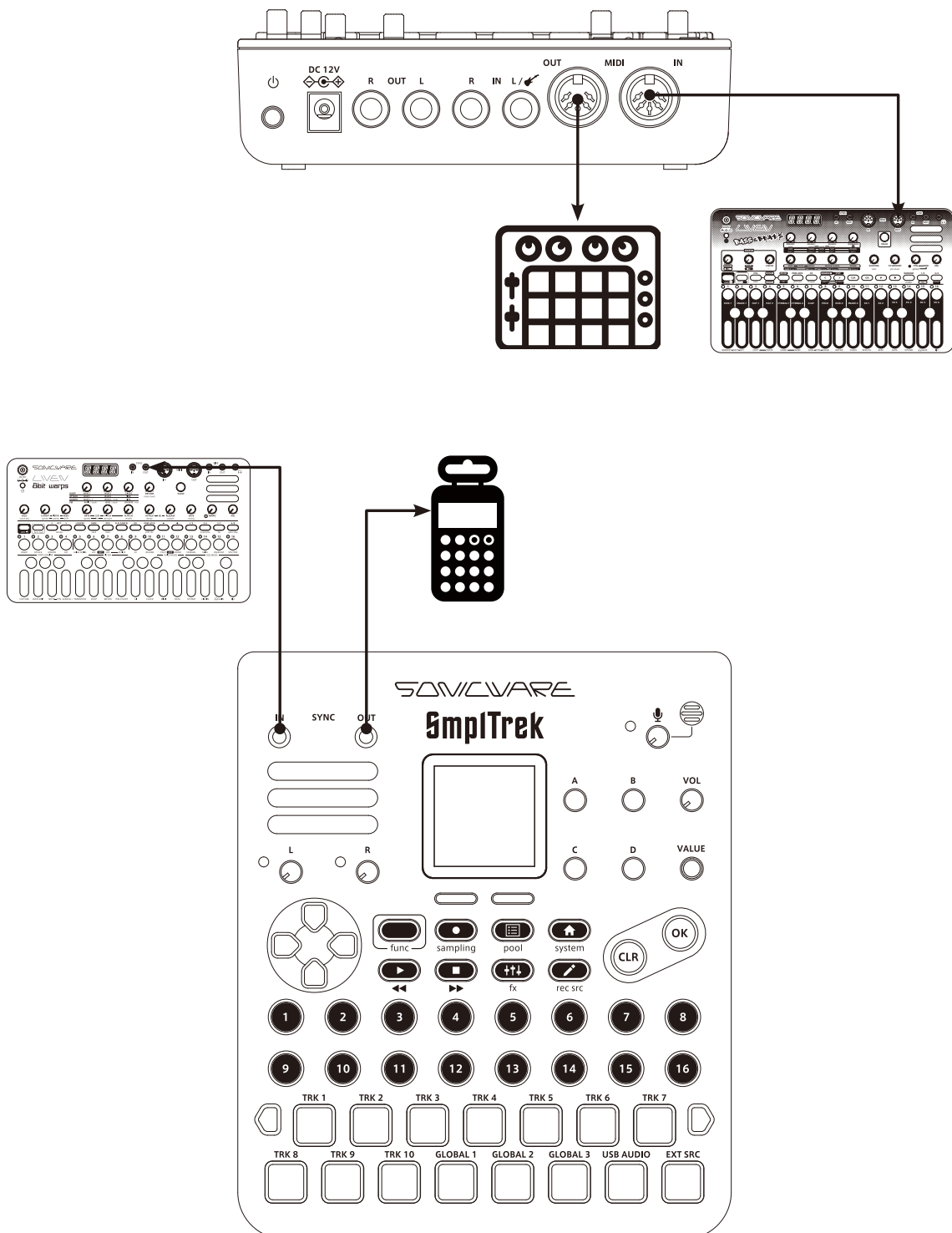

Clock synchronization with external devices

Setting the clock

- 1 Press **func** + **system** to open the SYSTEM MENU Screen.



- 2 Select **CLOCK**, and press **OK**.



- 3 Adjust the items on the settings screen that opens.



Clock synchronization with external devices

Clock		
🗑️ A	SOURCE	INTERNAL Use the built in clock. The SmpITrek will operate as the master when used by itself or synchronizing other devices.
		MIDI The SmpITrek will synchronize with MIDI clock received through the MIDI IN.
		SYNC The SmpITrek will synchronize with clock signals received through the SYNC IN.
🗑️ B	TEMPO LED	The LED will light along with the synchronized tempo.
🗑️ C	POLARITY IN	This switches the polarity of the SYNC IN jack between RISE (+ / waveform rising) and FALL (– / waveform falling). Set this to match the sync polarity of the connected device.
🗑️ D	POLARITY OUT	This switches the polarity of the SYNC OUT jack between RISE (+ / waveform rising) and FALL (– / waveform falling). Set this to match the sync polarity of the connected device.

MIDI

Setting track MIDI channels

MIDI channel numbers can be set for every SmpITrek track.

- 1 Press **func** + **system** to open the SYSTEM MENU Screen.
- 2 Select **MIDI**, and press **OK** to open the MIDI SETTING Screen.



- 3 Select **TRACK**, and press **OK**.



- 4 Use **⌘** to select the track to change, and turn **⌘A** to change the channel.



MIDI





Setting MIDI channels for the unit

- 1 Press **func** + **system** to open the SYSTEM MENU Screen.
- 2 Select **MIDI**, and press **OK** to open the MIDI SETTING Screen.



- 3 Select **CHANNEL**, and press **OK**.



Clock		
 A	PROJECT CHANNEL	This channel is for receiving project level MIDI and other parameters related to the project
 B	AUTO CHANNEL	This is the channel number used when the OUTPUT CHANNEL is set to AUTO
 C	OUTPUT CHANNEL	Channel used for output AUTO : Use the AUTO CHANNEL number TRACK : Use channel numbers set for each track
 D	PC CHANNEL	This channel is for sending and receiving program changes Switching scenes is done with program changes

MIDI

Making other MIDI settings

- 1 Press **func** + **system** to open the SYSTEM MENU Screen.
- 2 Select **MIDI > CONFIG**.
- 3 Set each item.



Config 1/3

A	INPUT FROM	Set connectors used to receive MIDI
B	OUTPUT TO	Set connectors used to send MIDI
C	TX NOTE	Turn note transmission on/off
D	TX CC	Turn control change transmission on/off

Config 2/3

A	CLOCK OUT	Turn clock output on/off
B	OUT/THRU	Switch between MIDI OUT and THRU
C	COMMAND	Set command data transmitting (TX) and receiving (RX)
D	PROGRAM CHANGE	Set program change transmitting (TX) and receiving (RX)

Config 3/3

A	ACTIVE SENS	Set active sensing transmitting (TX) and receiving (RX)
----------	-------------	---

System settings

Pad sensitivity setting

- 1 Press **func** + **system** to open the SYSTEM MENU Screen.
- 2 Select **PAD VELOCITY**, and press **OK**.



- 3 Turn **⏸A** to adjust it.

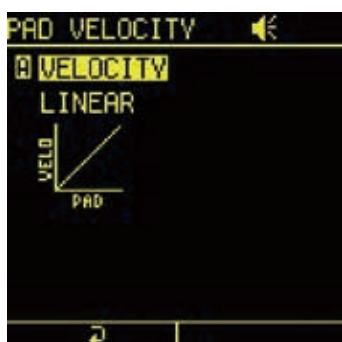

Pad Velocity

⏸A	VELOCITY	Set pad sensitivity
-----------	----------	---------------------

1 - 127	Velocity is always at this fixed value.
SOFT	This is best for people who play with a light touch. The sound will be loud even when tapped lightly.
LINEAR	The velocity will change linearly in response to how hard the LED pads are tapped.
HARD	This is best for people who play with a heavy touch.

System settings

Battery setting

1 Press **func** + **system** to open the SYSTEM MENU Screen.

2 Select **BATTERY**, and press **OK**.



3 Turn **⏻A** to adjust it.



Battery		
⏻A	BATTERY	Select battery type

ALKALINE	Alkaline batteries
NiMH	Nickel-metal hydride batteries
LITHIUM	Lithium batteries

System settings

Automatic power off function

1 Press **func** + **system** to open the SYSTEM MENU Screen.

2 Select **AUTO POWER OFF**, and press **OK**.



3 Turn **⏸A** to adjust it.



Auto Power Off		
⏸A	AUTO POWER OFF	Set time until power turns off automatically

System settings

Resetting the unit to the factory default state

- 1 Press **func** + **system** to open the SYSTEM MENU Screen.
- 2 Select **RESET**, and press **OK**.



- 3 Select **YES**, and press **OK**.

POINT!

- Be careful because this will reset all settings in the SmpITrek to their factory defaults..
- This will not format the card.

System settings

Checking system version information

- 1 Press **func** + **system** to open the SYSTEM MENU Screen.



- 2 Select **INFORMATION**, and press **OK**.



Card functions

Card reader mode

- 1 Press **func** + **system** to open the SYSTEM MENU Screen.
- 2 Select **CARD**, and press **OK**.



- 3 Select **CARD READER**, and press **OK**.



- 3 Select **YES**, and press **OK**.



Card functions

Testing card performance

The performance of the card being used can be measured to determine whether it can be used with the SmpITrek.

- 1 Press **func** + **system** to open the SYSTEM MENU Screen.
- 2 Select **CARD**, and press **OK**.



- 3 Select **PERFORMANCE TEST** and press **OK**.

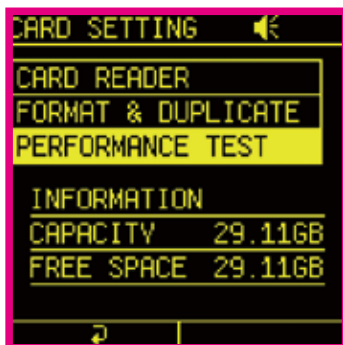

- 4 Press **OK** to start the test.



RESULT : OK	The card can be used with the SmpITrek.
RESULT : NG	The card cannot be used with the SmpITrek.

Card functions

Formatting

- 1 Press **func** + **system** to open the SYSTEM MENU Screen.
- 2 Select **CARD**, and press **OK**.



- 3 Select **FORMAT & DUPLICATE**, and press **OK**.

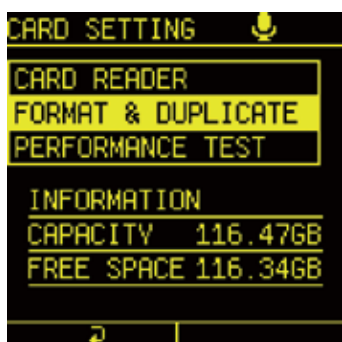

- 4 Select **YES**, and press **OK**.



POINT!



- Be careful because this will erase all data on the card.

Firmware updates

Updating the firmware

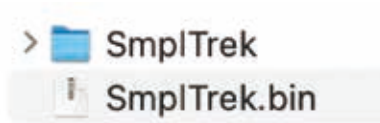
- 1 Copy the downloaded firmware (.bin) to the root folder on the card.



- 2 While pressing , press and hold the power button.
- 3 When the update Screen opens, select **SYSTEM UPDATE**, and press .
- 4 Select **YES**, and press  to start the update.
- 5 After it completes, press the power button to shut the unit down. Then, restart it.

Specs

Maximum Polyphony	<p>35 voices</p> <ul style="list-style-type: none"> • LOOP track + SHOT track + DRUM track + INST track: 30 voices • GLOBAL audio track: 3 voices (3 mono tracks) • USB audio track: 1 voice • External source: 1 voice <p>(DRUM track and INST track have a maximum of 8 voices each track. MIDI track can also output up to 8 notes each track.)</p>
Sampling/Recording	<p>48kHz-16bit linear</p> <p>Sampling Time: Maximum sampling time (size) for a single sample is approximately 180 minutes in stereo (2 GB).</p> <p>Recordable Data: Depend on SD card *SD card sold separately</p> <p>Data Format: WAV</p> <p>Resampling, auto-slicing, time-stretching, pitch-changing functions</p> <p>*SmpITrek requires an SD card for sampling. Supported SD cards are SDHC cards up to 32 GB. (SDXC cards are not supported.)</p>
Sequencer	<p>Each song project has 16 scenes</p> <p>1 scene contains 10 sequencer tracks and 3 additional audio tracks</p> <p>Track Type</p> <ul style="list-style-type: none"> • Loop Track: Sequencer for a looping sample (Max 10 tracks/project) • Shots Track: Sequencer for a single one-shot sample (Max 10 tracks/project) • Drum Track: Step sequencer for drums (Max 1 track/project) • Instrument Track: Piano roll style sequencer for musical instruments (Max 3 tracks/project) • MIDI Track: Piano roll style sequencer for external MIDI equipment. (Max 10 tracks/project) <p>Max. number of bars: 128 bars in Scene</p> <p>Note Length: 1/1 ~ 1/32</p> <p>Various copy functions</p> <p>Transpose function</p> <p>Real-time and non-real-time recording</p> <p>Metronome, pre-count function</p>
Effects	36 types (Insert, Send, Master Effects)
Pads	15 velocity-sensitive pads with RGB LEDs
Controllers	Control knob x 5, Directional pad with 2 button controls
Display	1.5 inch OLED display
Built-in Mic	Mono x 1 (Omni-directional, 94dB SPL)
Built-in Speaker	Mono x 1 (1.5W 4 Ω)
Connectors	<p>INPUT L / Guitar (Switchable 10k Ω and 1M Ω impedance) / Dynamic Mic</p> <p>[LINE Gain] PAD: -20dB</p> <p>[Hi-Z Gain] LOW: 0dB, NORMAL: +10dB, HI: +20dB</p> <p>[MIC Gain] LOW: 0dB, NORMAL: +10dB</p> <p>INPUT R / Dynamic Microphone</p> <p>[LINE Gain] PAD: -20dB</p> <p>[MIC Gain] LOW: 0dB, NORMAL: +28.8dB, HI: +50dB</p> <p>STEREO LINE OUTPUTS (Max +6.5dBV)</p> <p>*The above jacks are all balanced 1/4" TRS Jack Connectors</p> <p>PHONES jack (stereo 3.5mm mini jack type)</p>

Specs

Connectors	<p>USB port (micro USB Type-B) [USB Audio] USB 2.0 Full Speed, 48kHz-16bit Input: 2 channels, Output: 2 channels [USB MIDI] [Mass Storage Class] USB2.0 High Speed</p> <p>*For iPhone, Apple Lightning to USB Camera Adapter required separately</p> <p>MIDI IN connector (5-Pin DIN type) MIDI OUT connector (5-Pin DIN type) AUDIO SYNC IN jack (mono 3.5mm mini jack type) AUDIO SYNC OUT jack (mono 3.5mm mini jack type) SD card slot DC IN connector</p>
Power Supply	<p>DC12V output AC adapter (500mA, Inner Diameter: 2.1mm, Outer Diameter: 5.5mm, Polarity: Center +) Ni-MH AA SIZE Rechargeable Battery or Alkaline AA SIZE Dry Battery x 6 (Alkaline dry batteries life: approx. 4 hours)</p> <p>*Batteries sold separately</p>
Accessories	<p>AC Adaptor Warranty</p> <p>*SD card, USB cable and the other connection cables sold separately</p>
Size and weight	<p>Width: 147mm approx. 5.8 inch Depth: 175mm approx. 7.8 inch Height: 46mm approx. 1.8 inch Weight: 550g approx. 1 lbs 3.5 oz</p>
Bottom side	<p>screw hole (1/4-20UNC)</p>

FCC regulation warning (for USA)

Note: This equipment has been tested and found to comply with the limits for a Class B digital device, pursuant to part 15 of the FCC Rules. These limits are designed to provide reasonable protection against harmful interference in a residential installation. This equipment generates, uses and can radiate radio frequency energy and, if not installed and used in accordance with the instructions, may cause harmful interference to radio communications. However, there is no guarantee that interference will not occur in a particular installation. If this equipment does cause harmful interference to radio or television reception, which can be determined by turning the equipment off and on, the user is encouraged to try to correct the interference by one or more of the following measures:

- Reorient or relocate the receiving antenna.
- Increase the separation between the equipment and receiver.
- Connect the equipment into an outlet on a circuit different from that to which the receiver is connected.
- Consult the dealer or an experienced radio/TV technician for help.

Legal disclaimers

Sonicware Inc. (hereafter, "SONICWARE") strives to assure that this document is as accurate and current as possible, but will bear no responsibility for any compensation claims or losses due to content included in this document. Moreover, information in this document could be changed without notice. SONICWARE retains the right to change product specifications and programs at any time. SONICWARE will bear no responsibility for any errors depicted in this document. SONICWARE will bear no responsibility for any losses resulting from the use of this information, functions or performance, regardless of contracts, lack of caution or other conduct.

Copyrights and registered trademarks

- SONICWARE is a registered trademark of Sonicware Inc.
- MIDI is a registered trademark of the Association of Musical Electronics Industry (AMEI).
- Other company names, product names, standard names and registered trademarks in this document are the property of their respective owners.
- All the trademarks and registered trademarks in this document are not intended to violate the copyrights of their owners, but rather are included for the purpose of identification only.
- Recording from copyrighted sources, including audio files, CDs, records, videos, tapes, broadcasts, streamed content and works of art, without permission of the copyright holder for any purpose other than personal use is prohibited by law.
- Sonicware Inc. will not assume any responsibility related to infringements of copyrights.

Important safety precautions

You must read the following precautions in order to use the product safely and prevent accidents.

WARNING: Failure to follow these precautions could result in serious harm to the user or even death.

- Operation using an AC adapter

Do not do anything that could exceed the ratings of outlets and other electrical wiring equipment.

Disconnect the AC adapter from the outlet when lightning occurs and when not using it for a long time.

- Operation using batteries

Use commercially available 1.5V AA dry cell batteries.

Carefully read the precautions of the batteries being used.

Be sure to insert the batteries with +/ – ends oriented correctly.

Do not use new and old batteries together. Do not use batteries of different types together.

Remove the batteries when they will not be used for a long time.

If a leak occurs, thoroughly wipe the battery compartment and battery terminals to remove the leaked fluid.

- Do not open the case and disassemble or modify the product.
- Do not drop, strike or apply excessive force to the unit.
- Do not put liquid on or in the unit.
- Do not put foreign objects into the case.
- Do not use at a loud volume. Doing so could generate loud volumes that might lead to hearing loss.
- When transferring this unit, use the individual packing box and cushioning material that it came with when purchased new.
- When the unit is powered on, do not wrap it in cloth, plastic or other materials.
- Do not step on or apply pressure to the power cord.
- Do not use in the following environmental conditions. Doing so could cause malfunction.
 - Locations in direct sunlight, environments that exceed 40°C, or near stoves and other heat sources
 - Locations with extremely low or high temperatures
 - Locations with extremely high humidity or where the product could become wet
 - Locations with frequent vibrations or much dust or sand
- If the unit becomes broken or malfunctions, immediately turn the power off and stop using it.

Usage Precautions

Failure to follow these precautions could cause injury to the user and physical damage.

- When connecting cables or working with the power of the unit, minimize the input levels of connected devices or turn them off.
- Cleaning
 - If the screen or the case become dirty, wipe them gently with a soft cloth.
 - Do not use chemicals, including alcohol, benzene, thinner or cleansers.
 - If this does not clean them, wipe them with a slightly damp cloth that has been wrung out well.
 - Do not turn the power on until the product is completely dry.